



 *Attrezzature per la ristorazione*

 *Catering equipment*

2026/2027

TERMIKA

CENIK IZDELKOV



-20% na vse izdelke v katalogu

Icemax uradni zastopnik za področje Slovenije



Condizioni generali di vendita

Il presente catalogo/listino annulla e sostituisce tutti i precedenti.

I dati tecnici e le foto riportati in questo catalogo/listino sono indicativi.

Le caratteristiche tecniche ed estetiche dei prodotti possono variare in qualsiasi momento senza alcun obbligo di preavviso.

L'ordine da parte del cliente implica l'accettazione integrale delle presenti condizioni generali di vendita. Qualsiasi variazione alle presenti, se non espressamente confermata per iscritto da Amitek Srl, è da ritenersi nulla.

I prezzi si intendono IVA e trasporto esclusi. Amitek Srl si riserva il diritto di modificare i prezzi in qualunque momento senza obbligo di preavviso. I prezzi applicati da ritenersi validi sono sempre quelli indicati sulla conferma d'ordine inviata al cliente.

Tempi di consegna: secondo la disponibilità dei prodotti ordinati. I tempi di consegna verranno indicati nella conferma d'ordine, ma sono da ritenersi puramente indicativi. Eventuali ritardi non potranno costituire motivo di rivalsa o richiesta di risarcimento danni per nessun motivo.

Condizioni di pagamento: da definirsi con il nostro ufficio commerciale. Si richiede il pagamento anticipato in caso di: prime forniture, ordini di ricambi e superamento dei limiti di fido. Qualunque ritardo nei pagamenti concordati, comporterà la sospensione di ogni ulteriore fornitura.

Costo di gestione ordine: In caso di ordini di importo inferiore a 150,00€, verrà applicato un costo fisso di gestione ordine di 10,00€ (iva esclusa).

Costo dell'imballo: imballo standard (imballo in cartone e/o pallet, ove previsto) incluso nel prezzo.

Condizioni di trasporto (spedizioni in Italia): se non diversamente concordata, la consegna dei prodotti avverrà (EXW) franco fabbrica nostro stabilimento sede di Via Santo Marino, 250 - 47824 Poggio Torriana (RN) - Italia. In caso di resa in porto franco, verrà addebitato il costo del trasporto in fattura. Amitek Srl controlla sempre accuratamente il perfetto stato delle merci e dell'imballaggio prima della spedizione, in ogni caso la merce viaggia sempre a rischio e pericolo del committente, anche quando venduta in porto franco. In caso di trasporto in porto franco, prima di accettare la consegna, controllare che la merce ricevuta sia perfettamente integra. In caso si riscontri la minima anomalia nelle condizioni della merce o dell'imballo è indispensabile scrivere chiaramente e in maniera molto specifica su bollettino di consegna e DDT l'anomalia riscontrata (es: scatola ammaccata sul lato sx, pallet danneggiato, merce ammaccata ecc.) e che si accetta la merce con riserva in quanto collo non integro. In caso di mancata osservazione di queste istruzioni, Amitek Srl non risponderà in nessun caso di avarie o danneggiamenti riscontrati sulla merce e non effettuerà alcun tipo di rimborso o sostituzione.

Installazione: L'installazione, l'eventuale assemblaggio e la messa in funzione delle apparecchiature sono sempre a carico dell'acquirente originario.

Garanzia: La garanzia si intende applicata solo nei confronti dell'acquirente originario ed è valida per 12 mesi dalla data di acquisto salvo ove diversamente ed espressamente indicato, in caso di eventuali difetti di fabbricazione. Sono escluse dalla garanzia le parti elettriche (termostati, centraline di controllo, compressori, lampade, alimentatori, ecc.) e quelle soggette ad usura (cinghie, ruote, ecc.). Sono sempre esclusi dalla garanzia i danni causati dall'uso non corretto, da cattiva manutenzione ed imperizia. La garanzia non contempla le spese di manodopera e qualsiasi altra spesa accessoria (trasporti, trasferte, ecc.), così come il risarcimento di danni diretti o indiretti derivanti dal non funzionamento della macchina. La sostituzione di eventuali pezzi di ricambio o parti difettose dovrà essere concordata con il nostro ufficio assistenza tecnica. Qualsiasi reso dei prodotti potrà avvenire solo dopo autorizzazione del nostro ufficio commerciale e con trasporto in porto franco alla nostra sede di Poggio Torriana (RN). Qualunque reso non autorizzato verrà respinto.

Assistenza tecnica: L'assistenza è a carico dell'acquirente originario per tutta la durata della garanzia. Qualunque intervento di riparazione richiesto ad Amitek Srl, verrà effettuato esclusivamente presso la nostra sede di Poggio Torriana (RN).

Riserva di proprietà: il materiale venduto rimane di proprietà di Amitek Srl fino al completo pagamento. Nel caso di mancato pagamento Amitek Srl si riserva la facoltà di riprendere possesso della merce. Tutte le nostre macchine sono coperte da assicurazione di responsabilità civile verso terzi, escluso U.S.A., Canada e Messico.

Indicazioni riportate nel catalogo: Amitek Srl si riserva il diritto di modificare, in qualsiasi momento e senza alcun obbligo di preavviso, le dimensioni e le caratteristiche dei prodotti elencati nel presente catalogo. Le illustrazioni, fotografie e descrizioni presenti nel catalogo in vigore al momento dell'accettazione dell'ordine si intendono come indicazioni generali, non costituiscono un vincolo e possono non corrispondere all'effettiva conformazione dei prodotti.

Illustrazioni ed immagini: I disegni, le immagini e le fotografie di vario genere presenti nel catalogo, così come quelli inviati da Amitek Srl insieme ad una proposta di fornitura, ad un contratto o simile, sono riservati e di esclusiva proprietà di Amitek Srl.

Marchi e brevetti: è fatto espresso divieto di utilizzare marchi e/o brevetti registrati da Amitek srl, senza un espresso consenso scritto. Per qualunque controversia le parti stabiliscono che l'unico foro competente è quello di Rimini.

Finito di stampare in aprile 2025

Salvo ove diversamente ed espressamente indicato, i prodotti del presente catalogo/listino sono fabbricati in Italia.



General sales conditions

This catalogue / price list cancels and replaces all previous ones.

Technical data and photos shown in this catalogue / price list are for illustrative purpose only.

Technical and aesthetic features of the products may vary at any time without any prior notice.

The customer order implies full acceptance of these general sales conditions. Any change to these conditions, unless

expressly confirmed by Amitek Srl in written form, are to be considered void.

Prices do not include VAT and transport fees. Amitek Srl reserves the right to change prices at any time without prior notice. The valid prices are always those indicated in the order confirmation sent to the customer.

Delivery times: according to the availability of the ordered products. Delivery times will be indicated in order confirmation, but are to be considered purely indicative. Any delay will not constitute grounds for compensation or claim for damage for any reason.

Payment conditions: to be defined with our sales department. We require advanced payment for: first deliveries, spare parts orders and orders exceeding granted credit. Any delay in agreed payment terms will result in the suspension of any further supply.

Handling and processing fees: In the case of orders of less than € 150,00, we will apply a fixed cost for handling and processing fees of € 10,00 (VAT excluded).

Packaging costs: standard packaging (cardboard and / or pallet packaging, where applicable) included in the price.

Transport conditions (international shipments): unless otherwise agreed, the delivery of the products will take place ex works (EXW) at our factory located in Via Santo Marino, 250 - 47824 Poggio Torriana (RN) - Italy. In case of shipment in DAP, transport cost will be charged on the invoice. Amitek Srl always carefully checks the perfect condition of the goods and packaging before shipment, in any case the goods always travel at the risk of the customer, even when shipped in DAP. Before accepting the delivery, the customer agrees to check with the forwarder that the received goods and packages are in perfect conditions and that the total number of received packages is as written in the delivery notes. In case of any damage or loss of the goods, any claim will have to be settled with the forwarder only. Amitek Srl will not be liable under any circumstances for any breakdowns or damage found on the goods and will not provide any type of refund or replacement.

Installation: The installation, any assembly and commissioning of the equipment are always the responsibility of the original purchaser.

Warranty terms: The warranty applies only to the original purchaser and is valid for 12 months from the date of purchase, unless otherwise expressly indicated, for any manufacturing defects. Warranty does not include electrical parts (thermostats, control units, compressors, lamps, power supplies, etc.) and those subject to wear (belts, wheels, etc.). Damages caused by incorrect use, poor maintenance and unskillfulness are always excluded from the warranty. Warranty does not cover labor costs or any other additional charges (transport, travel, etc.), as well as compensation for direct or indirect damages deriving from the non-functioning of the appliance. The replacement of any spare parts or defective parts must be agreed with our sales department. Any return of the products can only take place after authorization from our sales department and with transport in DAP to our headquarters in Poggio Torriana (Italy). Any unauthorized return will not be accepted.

Technical assistance: Assistance is the responsibility of the original purchaser for the entire duration of the warranty. Any repairs requested to Amitek Srl will be carried out exclusively at our headquarters in Poggio Torriana (Italy).

Retention of ownership: sold goods remain property of Amitek Srl until paid in full. In case the payment is not fulfilled, Amitek Srl reserves the right to take back the goods. All our machines are covered by third party liability insurance, excluding U.S.A., Canada and Mexico.

Information in the catalogue: Amitek Srl reserves the right to modify, at any time and without any prior notice, the dimensions and characteristics of the products listed in this catalogue. The illustrations, photographs and descriptions in the catalogue in force at the time of order acceptance are intended as general indications, are not binding and may not correspond to the actual conformation of the products.

Illustrations and images: The drawings, images and photographs of various kinds in the catalogue, as well as those sent by Amitek Srl together with a proforma invoice, a contract or similar, are reserved and exclusive property of Amitek Srl.

Trademarks and patents: the use of trademarks and / or patents registered by Amitek srl without express written consent is strictly forbidden.

In the event of any dispute, the court of Rimini (Italy) will have the sole and exclusive jurisdiction.

Printed in April, 2025

Except where otherwise clearly indicated, the products in this catalogue / price list are made in Italy.

Condizioni generali di vendita
General sales conditions

Pag. 2 - 3

Lavastoviglie
Dishwashers



Pag. 6 - 11

Friggitrici elettriche
Electric fryers



Pag. 12 - 15

Lampade riscaldanti a infrarosso
IR heating lamps

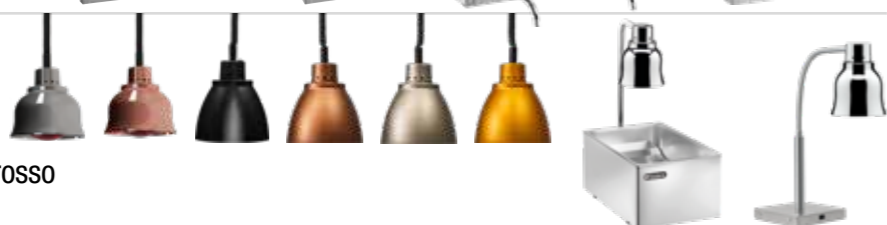

Pag. 16 - 20

Salamandre - Tostiere - Fry Top elettrici e a gas
Piastre di cottura - Crepiere
*Salamanders - Toasters - Electric and gas Fry Top
Cooking plates - Crêpe makers*



Pag. 21 - 26

Cuocipasta - Bagnomaria
Cuociuovo - Macchine per hot dog
*Pasta cookers - Bain Marie
Egg cooker - Hot dog machines*



Pag. 27 - 31

Piani caldi
Warming plate



Pag. 32 - 33

Fornelloni a gas
Gas cookers



Pag. 34 - 35

Scaldapiatti
Plate warmers



Pag. 36 - 37

Forni a convezione
Forni pizzeria
*Convection ovens
Pizza ovens*



Pag. 38 - 49

Stendipizza
Pizza dough rollers



Pag. 50 - 51

Affettatrici
Slicers



Pag. 52 - 61

Pelapatate
Lavacozze
*Potato peelers
Mussel washers*



Pag. 62 - 64

Cutter - Tagliaverdura
Mixer ad immersione
*Cutter - Vegetable cutters
Stick blenders*



Pag. 65 - 71

Tritacarne - Abbinati tritacarne/grattugia - Grattugie
Meat mincers - Meat mincers/graters - Graters



Pag. 72 - 75

Sottovuoto
Vacuum machines



Pag. 76 - 77



Lavastoviglie LSH a carica frontale

LSH front loading dishwashers



- Lavastoviglie a carico frontale con centralina elettronica con pochi comandi intuitivi per potere essere usate da qualsiasi tipo di utente.
- Struttura in acciaio inox AISI304.
- Pannello di chiusura fondo in plastica.
- Sorreggiporta «a fazzoletto» che garantisce un'estrema solidità.
- Bracci di lavaggio in materiale composito leggeri e con ugelli facilmente smontabili per pulizia e manutenzione.
- Ciclo di lavaggio da 120".

- Dosatore pneumatico brillantante di serie.
- Filtro pompa lavaggio.
- Iniettore del detersivo di serie.
- Piedini regolabili.

N.B.: Altezza massima scarico per versioni senza pompa di scarico: 5cm

* LSH5000-5001-5002 disponibili anche in versione 400/3N/50Hz, con sovrapprezzo di + € 100,00

- Front loading dishwashers with electronic controller and few intuitive controls to be used by even the less experienced users.
- AISI304 stainless steel structure.
- Bottom closing panel in plastic.
- Welded door holder guarantees maximum durability.
- Washing arms in lightweight composite material with easily removable nozzles for cleaning and maintenance.
- 120" wash cycle.

- Pneumatic rinse-aid pump included.
- Washing pump filter.
- Standard detergent injector.
- Adjustable feet.

Note: Maximum drain height for versions without drain pump: 5cm

* LSH5000-5001-5002 also available in 400/3N/50Hz version, with a price surcharge of + € 100,00

MODELLO MODEL	PREZZO PRICE	POTENZA WATT POWER WATT	ALIMENTAZIONE POWER SUPPLY	DIMENSIONE CESTELLO mm BASKET DIMENSION mm	ALTEZZA MAX. STOVIGLIE mm MAX. DISHES HEIGHT mm	CAPACITÀ VASCA L TANK CAPACITY L	DIMENSIONI mm DIMENSIONS mm	PESO NETTO Kg NET WEIGHT Kg	PESO LORDO Kg GROSS WEIGHT Kg	DIMENSIONI IMBALLO cm PACKING DIMENSIONS cm	MODELLO MODEL
LSH3500	€ 1.510,00	2950	230V/1N/50	350x350	250	12	425x455x640h	27	33	59x49x82h	LSH3500
LSH3501	€ 1.590,00	2950	230V/1N/50	350x350	250	12	425x455x640h	28	34	59x49x82h	LSH3501
LSH3502	€ 1.760,00	2950	230V/1N/50	350x350	250	12	425x455x640h	28	34	59x49x82h	LSH3502
LSH4000	€ 1.760,00	3000	230V/1N/50	400x400	290	14	475x505x720h	32	41	65x75x96h	LSH4000
LSH4001	€ 1.860,00	3000	230V/1N/50	400x400	290	14	475x505x720h	33	42	65x75x96h	LSH4001
LSH4002	€ 1.970,00	3000	230V/1N/50	400x400	290	14	475x505x720h	33	42	65x75x96h	LSH4002
LSH5000	€ 2.350,00*	3450	230V/1N/50*	500x500	320	29	590x600x820h	54	63	65x75x99h	LSH5000
LSH5001	€ 2.430,00*	3450	230V/1N/50*	500x500	320	29	590x600x820h	55	64	65x75x99h	LSH5001
LSH5002	€ 2.590,00*	3450	230V/1N/50*	500x500	320	29	590x600x820h	55	64	65x75x99h	LSH5002

Lavastoviglie LSH a carica frontale LSH front loading dishwashers



Se lo scarico del locale in cui viene installata l'apparecchiatura è posizionato più in alto rispetto a quello della lavastoviglie, è necessario acquistare una macchina con pompa di scarico (LSH3502, LSH4002, LSH5002).

If the drain of the room where the appliance is installed is placed higher than the one of the dishwasher, it is necessary to buy an appliance equipped with a drain pump (LSH3502, LSH4002, LSH5002).

LSH3500
LSH3501
LSH3502

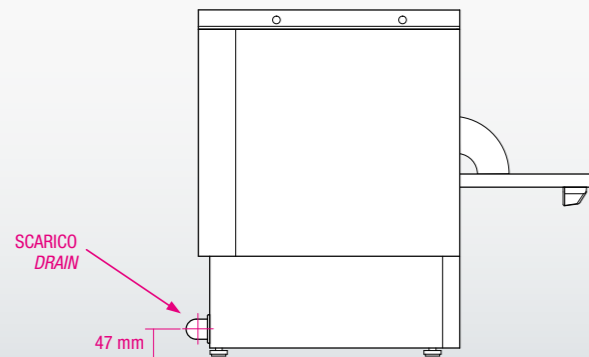

LSH4000
LSH4001
LSH4002

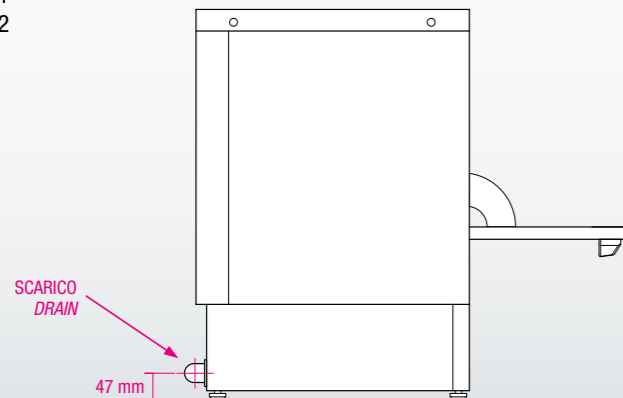

LSH5000
LSH5001
LSH5002

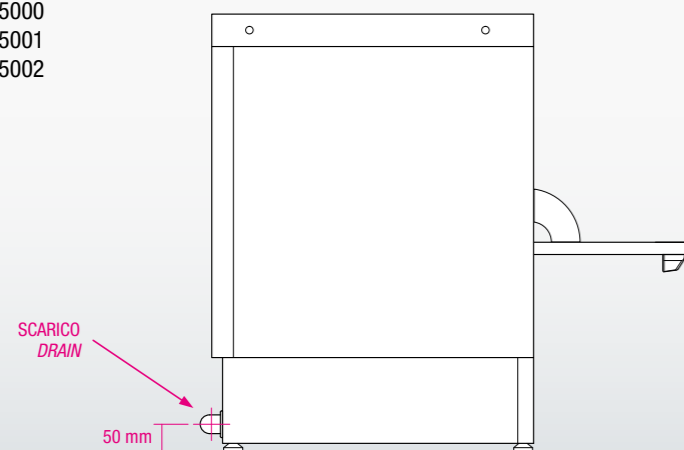

CESTO BICCHIERI
GLASS BASKET



CESTO PIATTI
DISH BASKET

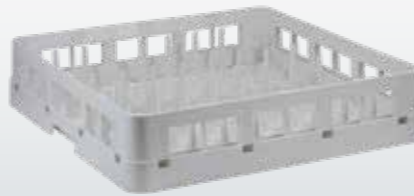

CESTO TONDO
ROUND BASKET

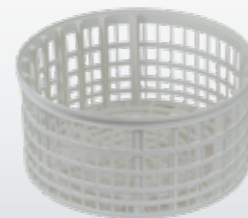

CONTENITORE POSATE
CUTLERY HOLDER



INSERTO PIATTINI
SMALL PLATES INSERT

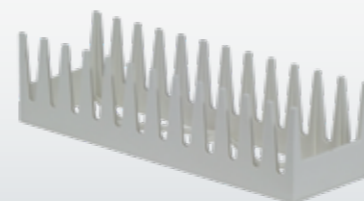

MODELLO / MODEL	DOTAZIONE STANDARD	STANDARD EQUIPMENT
LSH3500	1 cestello bicchieri 35x35cm, 1 contenitore posate, dosatore pneumatico brillantante	1 basket for glasses of 35x35cm, 1 cutlery holder, pneumatic rinse-aid pump
LSH3501	1 cestello bicchieri 35x35cm, 1 contenitore posate, dosatore pneumatico brillantante, dosatore peristaltico detergente	1 basket for glasses of 35x35cm, 1 cutlery holder, pneumatic rinse-aid pump, peristaltic timed detergent pump
LSH3502	1 cestello bicchieri 35x35cm, 1 contenitore posate, dosatore pneumatico brillantante, dosatore peristaltico detergente, pompa di scarico	1 basket for glasses of 35x35cm, 1 cutlery holder, pneumatic rinse-aid pump, peristaltic timed detergent pump, drain pump
LSH4000	1 cestello bicchieri 40x40cm, 1 contenitore posate, dosatore pneumatico brillantante	1 basket for glasses of 40x40cm, 1 cutlery holder, pneumatic rinse-aid pump
LSH4001	1 cestello bicchieri 40x40cm, 1 contenitore posate, dosatore pneumatico brillantante, dosatore peristaltico detergente	1 basket for glasses of 40x40cm, 1 cutlery holder, pneumatic rinse-aid pump, peristaltic timed detergent pump
LSH4002	1 cestello bicchieri 40x40cm, 1 contenitore posate, dosatore pneumatico brillantante, dosatore peristaltico detergente, pompa di scarico	1 basket for glasses of 40x40cm, 1 cutlery holder, pneumatic rinse-aid pump, peristaltic timed detergent pump, drain pump
LSH5000	1 cestello bicchieri 50x50cm, 1 cestello piatti 50x50cm, 1 contenitore posate, dosatore pneumatico brillantante	1 basket for glasses of 50x50cm, 1 dish basket of 50x50cm, 1 cutlery holder, pneumatic rinse-aid pump
LSH5001	1 cestello bicchieri 50x50cm, 1 cestello piatti 50x50cm, 1 contenitore posate, dosatore pneumatico brillantante, dosatore peristaltico detergente	1 basket for glasses of 50x50cm, 1 dish basket of 50x50cm, 1 cutlery holder, pneumatic rinse-aid pump, peristaltic timed detergent pump
LSH5002	1 cestello bicchieri 50x50cm, 1 cestello piatti 50x50cm, 1 contenitore posate, dosatore pneumatico brillantante, dosatore peristaltico detergente, pompa di scarico	1 basket for glasses of 50x50cm, 1 dish basket of 50x50cm, 1 cutlery holder, pneumatic rinse-aid pump, peristaltic timed detergent pump, drain pump

MODELLO / MODEL	ACCESSORI	ACCESSORIES	PREZZO / PRICE
CLS01	Cestello quadrato bicchieri 35x35cm (LSH3500-3501-3502)	Glass square basket 35x35cm (LSH3500-3501-3502)	€ 55,00
CLS02	Cestello quadrato bicchieri 40x40cm (LSH4000-4001-4002)	Glass square basket 40x40cm (LSH4000-4001-4002)	€ 60,00
CLS03	Cestello quadrato bicchieri 50x50cm (LSH5000-5001-5002)	Glass square basket 50x50cm (LSH5000-5001-5002)	€ 66,00
CLS04	Cestello quadrato piatti 50x50cm (LSH5000-5001-5002)	Dish square basket 50x50cm (LSH5000-5001-5002)	€ 66,00
CLS06	Cesto tondo bicchieri Ø 36cm (LSH3500-3501-3502)	Round glass basket Ø 36cm (LSH3500-3501-3502)	€ 55,00
CLS07	Cesto tondo bicchieri Ø 40cm (LSH4000-4001-4002)	Round glass basket Ø 40cm (LSH 4000-4001-4002)	€ 84,00
CLS08	Contenitore posate	Cutlery holder	€ 20,00
CLS09	Inserto piattini (12 posti) per tutti i cestelli	Small plates insert (12 places) for all baskets	€ 26,00



Lavastoviglie LSH a capote LSH Hood dishwasher



- LSH6000
- LSH6001
- LSH6002

Se lo scarico del locale in cui viene installata l'apparecchiatura è posizionato più in alto rispetto a quello della lavastoviglie, è necessario acquistare una macchina con pompa di scarico (LSH6002).

If the drain of the room where the appliance is installed is higher than the one of the dishwasher, it is necessary to buy an appliance equipped with a drain pump (LSH6002).

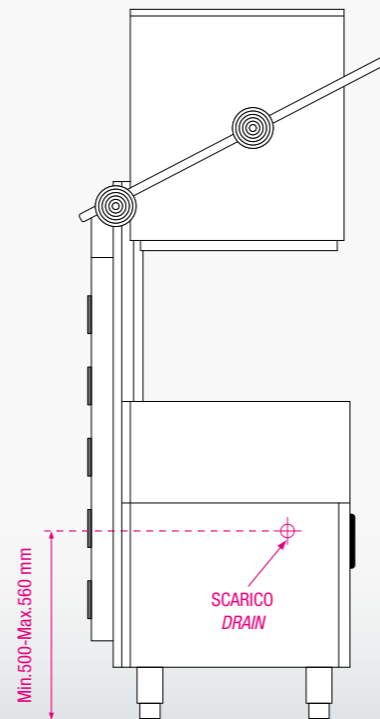

- Lavastoviglie a capote a gestione totalmente elettromeccanica.
- Struttura in acciaio inox AISI304.
- Bracci di lavaggio in materiale composito leggeri e con ugelli facilmente smontabili per pulizia e manutenzione.
- Giranti di lavaggio e risciacquo superiore ed inferiore.
- Cicli di lavaggio da 90" e 180".
- Dosatore pneumatico brillantante di serie.
- Iniettore del detersivo di serie.
- Filtro pompa lavaggio e filtro vasca.
- Piedini regolabili.

- Hood dishwasher with full electro-mechanic functioning.
- AISI304 stainless steel structure.
- Wash arms in lightweight composite material with easily removable nozzles for cleaning and maintenance.
- Upper and lower rotating spray arms.
- Wash cycles of 90" and 180".
- Pneumatic rinse-aid pump included.
- Standard detergent injector.
- Washing pump and tank filters.
- Adjustable feet.

N.B.: Altezza massima scarico per versioni senza pompa di scarico: 50 cm

Note: Maximum drain height for versions without drain pump: 50 cm



CESTO BICCHIERI
GLASS BASKET



CESTO PIATTI
DISH BASKET



CONTENITORE POSATE
CUTLERY HOLDER

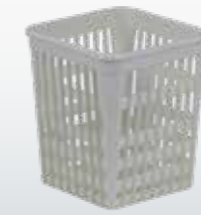

INSERTO PIATTINI
SMALL PLATES INSERT



MODELLO / MODEL	DOTAZIONE STANDARD	STANDARD EQUIPMENT	
LSH6000	1 cestello bicchieri 50x50cm, 2 cestelli piatti 50x50cm, 3 contenitori posate, dosatore pneumatico brillantante	1 glass basket 50x50cm, 2 dish baskets 50x50cm, 3 cutlery holders, pneumatic rinse-aid pump	
LSH6001	1 cestello bicchieri 50x50cm, 2 cestelli piatti 50x50cm, 3 contenitori posate, dosatore pneumatico brillantante, dosatore peristaltico detergente	1 glass basket 50x50cm, 2 dish baskets 50x50cm, 3 cutlery holders, pneumatic rinse-aid pump, peristaltic timed detergent pump	
LSH6002	1 cestello bicchieri 50x50cm, 2 cestelli piatti 50x50cm, 3 contenitori posate, dosatore pneumatico brillantante, dosatore peristaltico detergente, pompa di scarico	1 glass basket 50x50cm, 2 dish baskets 50x50cm, 3 cutlery holders, pneumatic rinse-aid pump, peristaltic timed detergent pump, drain pump	
MODELLO / MODEL	ACCESSORI	ACCESSORIES	PREZZO / PRICE
CLS03	Cestello quadrato bicchieri 50x50cm	Glass square basket 50x50cm	€ 66,00
CLS04	Cestello quadrato piatti 50x50cm	Dish square basket 50x50cm	€ 66,00
CLS08	Contenitore posate	Cutlery holder	€ 20,00
CLS09	Inserto piattini (12 posti) per tutti i cestelli	Small plates insert (12 places) for all baskets	€ 26,00

MODELLO / MODEL	PREZZO / PRICE	POTENZA WATT / POWER WATT	ALIMENTAZIONE / POWER SUPPLY	DIMENSIONE CESTELLO mm / BASKET DIMENSION mm	ALTEZZA MAX. STOVIGLIE mm / MAX. DISHES HEIGHT mm	CAPACITÀ VASCA L / TANK CAPACITY L	DIMENSIONI mm / DIMENSIONS mm	PESO NETTO Kg / NET WEIGHT Kg	PESO LORDO Kg / GROSS WEIGHT Kg	DIMENSIONI IMBALLO cm / PACKING DIMENSIONS cm	MODELLO / MODEL
LSH6000	€ 4.400,00	6750	400V/3N/50Hz	500x500	430	55	700x760x1460h	105	122	75x81x161h	LSH6000
LSH6001	€ 4.500,00	6750	400V/3N/50Hz	500x500	430	55	700x760x1460h	106	123	75x81x161h	LSH6001
LSH6002	€ 4.700,00	6750	400V/3N/50Hz	500x500	430	55	700x760x1460h	106	123	75x81x161h	LSH6002



Friggitrici elettriche

Electric fryers



- Struttura in acciaio inox
- Termostato di lavoro (50-180 °C) e di sicurezza
- Microinterruttore

- Zona fredda
- Resistenze removibili
- I modelli FC sono dotati di contattore

- *Stainless steel body*
- *Work (50-180 °C) and safety thermostat*
- *Micro switch*

- *Cold zone*
- *Removable heating elements*
- *The models FC are equipped with contactor*

MODELLO MODEL	PREZZO PRICE	POTENZA WATT POWER WATT	ALIMENTAZIONE POWER SUPPLY	CAPACITÀ OLIO Lt. OIL CAPACITY Lt.	DIMENSIONI mm DIMENSIONS mm	DIMENSIONI CESTO mm BASKET DIMENSIONS mm	PESO NETTO Kg NET WEIGHT Kg	PESO LORDO Kg GROSS WEIGHT Kg	DIMENSIONI IMBALLO cm PACKING DIMENSIONS cm	MODELLO MODEL
FE4	€ 220,00	2000	230/1N/50-60	3	245x430x310h	140x240x100h	4,80	5,50	50x27x34h	FE4
FE4S	€ 240,00	3200	230/1N/50-60	3	245x430x310h	140x240x100h	4,90	5,65	50x27x34h	FE4S
FE44	€ 410,00	2000 + 2000	230/1N/50-60	3 + 3	430x430x310h	140x240x100h	8,50	9,60	50x44x34h	FE44
FE44S	€ 420,00	3200 + 3200	230/1N/50-60	3 + 3	430x430x310h	140x240x100h	8,80	9,85	50x44x34h	FE44S
FE8	€ 280,00	3250	230/1N/50-60	6	340x430x310h	220x240x100h	6,00	7,00	56x38x38h	FE8
FE8S	€ 300,00	3600	230/1N/50-60	6	340x430x310h	220x240x100h	6,00	7,00	56x38x38h	FE8S
FE88	€ 530,00	3250 + 3250	230/1N/50-60	6 + 6	620x430x310h	220x240x100h	10,50	12,00	60x50x38h	FE88
FE88S	€ 550,00	3600 + 3600	230/1N/50-60	6 + 6	620x430x310h	220x240x100h	10,50	12,00	60x50x38h	FE88S
FE8R	€ 390,00	3250	230/1N/50-60	6	340x430x355h	220x240x100h	7,10	8,10	56x38x38h	FE8R
FE88R	€ 730,00	3250 + 3250	230/1N/50-60	6 + 6	620x430x355h	220x240x100h	13,20	14,70	63x50x38h	FE88R
FC10L	€ 480,00	3250	230/1N/50-60	10	340x460x355h	220x240x100h	7,50	8,70	60x35x42h	FC10L
FC100L	€ 860,00	3250 + 3250	230/1N/50-60	10 + 10	620x460x355h	220x240x100h	13,70	15,70	63x60x42h	FC100L
FC10	€ 570,00	3500	230/1N/50-60	10	300x480x350h	220x240x100h	8,30	9,40	60x35x42h	FC10
FC100	€ 1.020,00	3500 + 3500	230/1N/50-60	10 + 10	600x480x350h	220x240x100h	15,60	17,40	63x60x42h	FC100



- Struttura in acciaio inox
- Termostato di lavoro (50-180 °C) e di sicurezza
- Microinterruttore
- Zona fredda
- Resistenze removibili

- Dotate di contattore
- Con rubinetto di scarico olio
- Livelli di potenza FC16M: 4-8-12 kW
- Livelli di potenza FC25M/FC250M: 6-12-18 kW

- *Stainless steel body*
- *Work (50-180 °C) and safety thermostat*
- *Micro switch*
- *Cold zone*
- *Removable heating element*

- *Equipped with a contactor*
- *With oil drain faucet*
- *Power levels for FC16M : 4 - 8 - 12 kW*
- *Power levels for FC25M/FC250M: 6 - 12 - 18 kW*

MODELLO MODEL	PREZZO PRICE	POTENZA WATT POWER WATT	ALIMENTAZIONE POWER SUPPLY	CAPACITÀ OLIO Lt. OIL CAPACITY Lt.	DIMENSIONI mm DIMENSIONS mm	DIMENSIONI CESTO mm BASKET DIMENSIONS mm	PESO NETTO Kg NET WEIGHT Kg	PESO LORDO Kg GROSS WEIGHT Kg	DIMENSIONI IMBALLO cm PACKING DIMENSIONS cm	MODELLO MODEL
FC12	€ 1.370,00	9000	400/3N/50-60	12	400x700x420h	210x280x120h	19,40	21,30	80x50x60h	FC12
FC120	€ 2.400,00	9000 + 9000	400/3N/50-60	12 + 12	800x700x420h	210x280x120h	35,00	43,50	87x78x60h	FC120
FC12M	€ 1.600,00	9000	400/3N/50-60	12	400x700x960h	210x280x120h	30,80	35,80	73x43x108h	FC12M
FC120M	€ 2.850,00	9000 + 9000	400/3N/50-60	12 + 12	800x700x960h	210x280x120h	55,00	62,50	90x80x108h	FC120M
FC16M	€ 2.050,00	12000	400/3N/50-60	16	400x700x950h	265x325x145h	33,80	36,80	73x43x109h	FC16M
FC18	€ 1.700,00	9000	400/3N/50-60	18	600x570x480h	460x320x120h	26,50	29,50	70x70x55h	FC18
FC25M	€ 2.500,00	18000	400/3N/50-60	25	400x700x940h	265x325x145h	34,00	41,00	73x43x112h	FC25M
FC250M	€ 4.500,00	18000+18000	400/3N/50-60	25 + 25	800x700x940h	265x325x145h	70,00	80,00	90x80x112h	FC250M



Lampade riscaldanti ad infrarosso

Infrared heating lamps



R LAMPADA ROSSA / RED LAMP
W LAMPADA BIANCA / WHITE LAMP

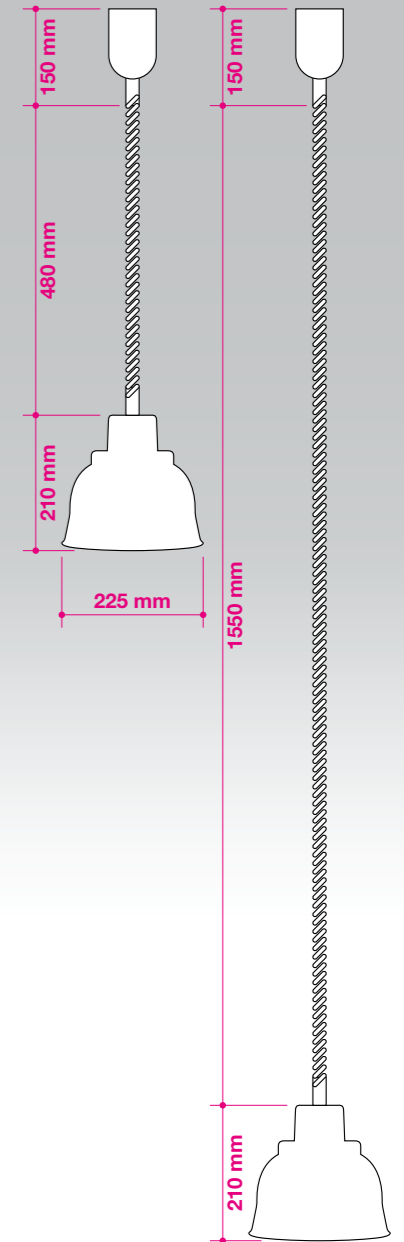
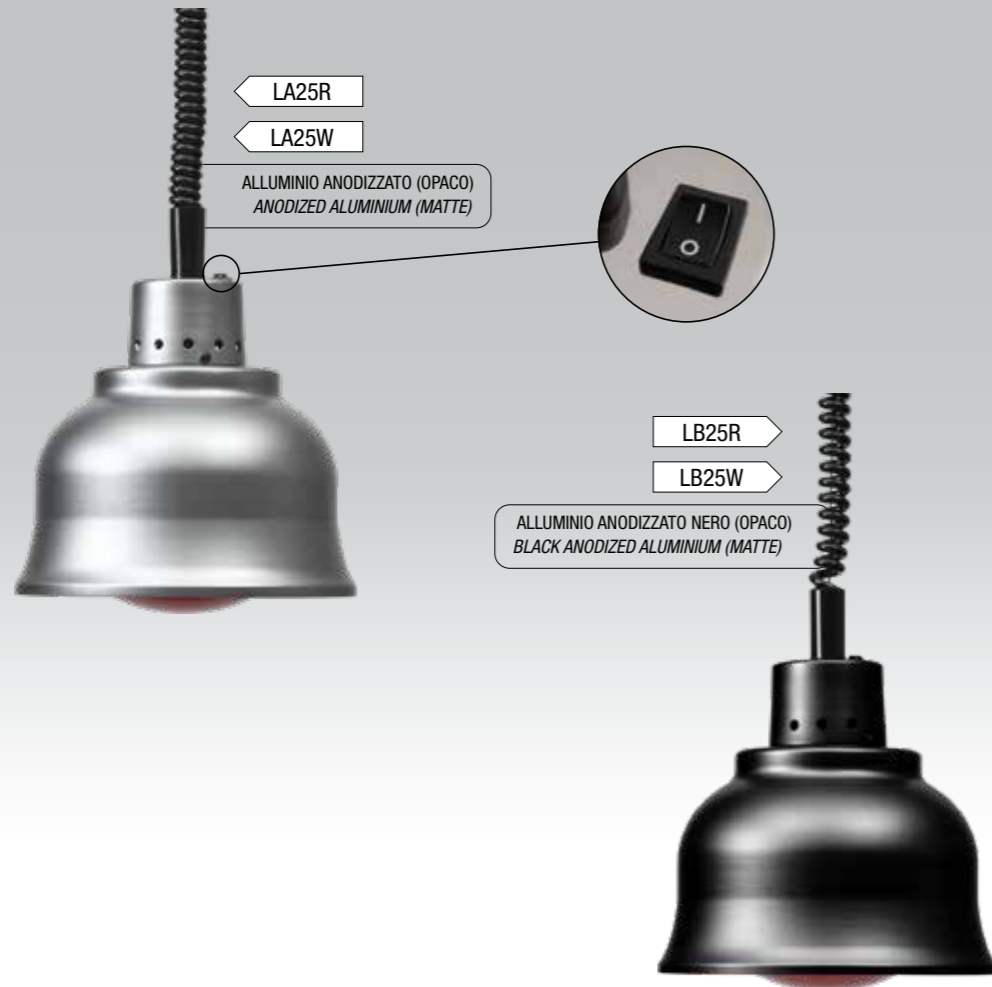

- Lampade riscaldanti ad infrarosso con estetica particolarmente curata, ideali per buffet e per il posizionamento a vista. Lavorazioni realizzate in Italia da artigiani specializzati e curate in ogni dettaglio.
- Struttura in alluminio / rame con lamiera da 1,5mm di spessore, a garanzia di grande solidità.
- Cavo spiralato estensibile.

- Saliscendi integrato e brevettato con frizione regolabile e capacità di peso massima di 5 Kg., che garantisce una regolazione in altezza semplice ed un'affidabilità di lunga durata.
- Interruttore ON/OFF sul corpo lampada.
- Corpo portalampada ceramico.
- Lampada ad infrarosso Philips certificata di altissima qualità, con vetro di colore rosso (versioni "R") o bianco (versioni "W").

- Infrared heating lamps with particularly refined aesthetics, ideal for buffets and in-sight positioning. Workmanship made in Italy by specialized craftsmen and cared for in every detail.
- Aluminum / copper structure with 1.5 mm thick sheet, to guarantee great solidity.
- Extendable spiral cable.

- Integrated and patented riser with adjustable friction and maximum weight capacity of 5 kg, which guarantees simple height adjustment and long-lasting reliability.
- ON / OFF switch on the lamp body.
- Ceramic lamp holder body.
- High quality certified Philips infrared lamp with red (versions "R") or white (versions "W") glass colors.

MODELLO MODEL	PREZZO PRICE	POTENZA WATT POWER WATT	ALIMENTAZIONE POWER SUPPLY	DIMENSIONI mm DIMENSIONS mm	PESO NETTO Kg NET WEIGHT Kg	PESO LORDO Kg GROSS WEIGHT Kg	DIMENSIONI IMBALLO cm PACKING DIMENSIONS cm	MODELLO MODEL
LA25R - LA25W	€ 220,00	250	230/1N/50-60	Ø 225	1,20	2,00	40x30x35h	LA25R - LA25W
LB25R - LB25W	€ 240,00	250	230/1N/50-60	Ø 225	1,20	2,00	40x30x35h	LB25R - LB25W
LC25R - LC25W	€ 330,00	250	230/1N/50-60	Ø 225	1,40	2,20	40x30x35h	LC25R - LC25W
LR25R - LR25W	€ 330,00	250	230/1N/50-60	Ø 225	1,40	2,20	40x30x35h	LR25R - LR25W



Lampade riscaldanti ad infrarosso

Infrared heating lamps



R LAMPADA ROSSA / RED LAMP
W LAMPADA BIANCA / WHITE LAMP

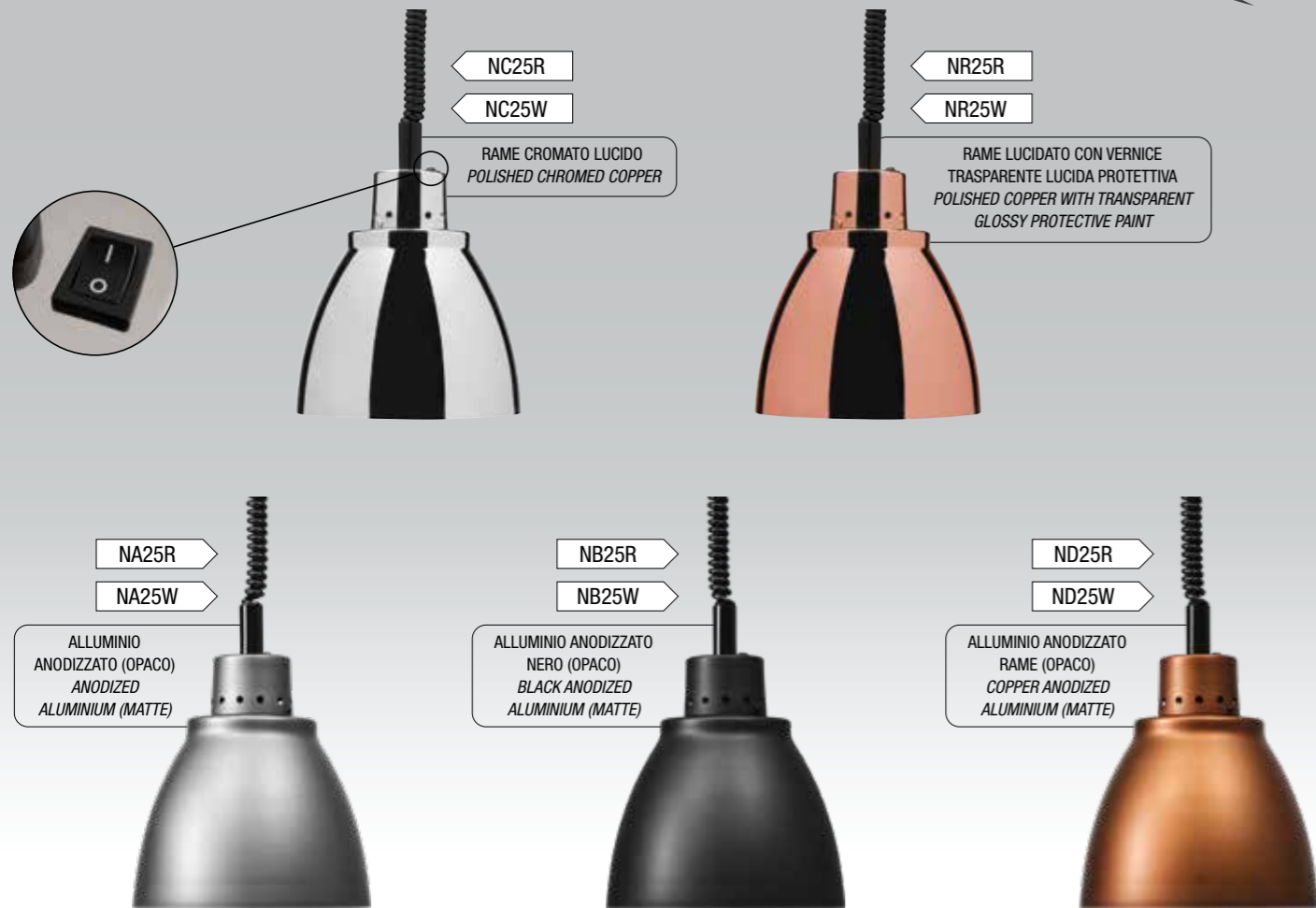

- Lampade riscaldanti ad infrarosso con estetica particolarmente curata, ideali per buffet e per il posizionamento a vista. Lavorazioni realizzate in **Italia** da artigiani specializzati e curate in ogni dettaglio.
- Struttura in alluminio / rame con lamiera da **1,5 mm** di spessore, a garanzia di grande solidità.
- Cavo spiralato estensibile.

- Saliscendi integrato e **brevettato** con frizione regolabile e capacità di peso massima di **5 Kg.**, che garantisce una regolazione in altezza semplice ed un'affidabilità di lunga durata.
- Interruttore ON/OFF sul corpo lampada.
- Corpo portalampana ceramico.
- Lampada ad infrarosso **Philips** certificata di altissima qualità, con vetro di colore rosso (versioni "R") o bianco (versioni "W").

- *Infrared heating lamps with particularly refined aesthetics, ideal for buffets and in-sight positioning. Workmanship made in **Italy** by specialized craftsmen and cared for in every detail.*
- *Aluminum / copper structure with **1.5 mm** thick sheet, to guarantee great solidity.*
- *Extendable spiral cable.*

- *Integrated and **patented** riser with adjustable friction and maximum weight capacity of **5 kg**, which guarantees simple height adjustment and long-lasting reliability.*
- *ON / OFF switch on the lamp body.*
- *Ceramic lamp holder body.*
- *High quality certified **Philips** infrared lamp with red (versions "R") or white (versions "W") glass colors.*

MODELLO MODEL	PREZZO PRICE	POTENZA WATT POWER WATT	ALIMENTAZIONE POWER SUPPLY	DIMENSIONI mm DIMENSIONS mm	PESO NETTO Kg NET WEIGHT Kg	PESO LORDO Kg GROSS WEIGHT Kg	DIMENSIONI IMBALLO cm PACKING DIMENSIONS cm	MODELLO MODEL
NC25R - NC25W	€ 340,00	250	230/1N/50-60	Ø 225	1,25	2,10	40x30x35h	NC25R - NC25W
NR25R - NR25W	€ 340,00	250	230/1N/50-60	Ø 225	1,25	2,10	40x30x35h	NR25R - NR25W
NA25R - NA25W	€ 240,00	250	230/1N/50-60	Ø 225	1,08	1,90	40x30x35h	NA25R - NA25W
NB25R - NB25W	€ 270,00	250	230/1N/50-60	Ø 225	1,08	1,90	40x30x35h	NB25R - NB25W
ND25R - ND25W	€ 240,00	250	230/1N/50-60	Ø 225	1,08	1,90	40x30x35h	ND25R - ND25W
NE25R - NE25W	€ 240,00	250	230/1N/50-60	Ø 225	1,08	1,90	40x30x35h	NE25R - NE25W
NF25R - NF25W	€ 240,00	250	230/1N/50-60	Ø 225	1,08	1,90	40x30x35h	NF25R - NF25W
NG25R - NG25W	€ 240,00	250	230/1N/50-60	Ø 225	1,08	1,90	40x30x35h	NG25R - NG25W
NH25R - NH25W	€ 240,00	250	230/1N/50-60	Ø 225	1,08	1,90	40x30x35h	NH25R - NH25W



Scaldfritt - Lampada da tavolo
Infrared warmers - Table lamp



Salamandre Salamanders



SCALDAFRITTI

- Struttura in acciaio inox
- Vasca GN1/1 h=16 cm con fondo forato
- Portalamпада in rame cromato Ø 175mm con interruttore 0-I
- Lampada rossa a raggi infrarossi da 250 watt

INFRARED WARMERS

- Stainless steel body
- Bowl GN1/1 h=16 cm with perforated bottom
- Lamp holder in chrome plated copper Ø 175mm, with switch 0-I
- 250 watt red infrared lamp

LAMPADA DA TAVOLO

- Basamento in acciaio inox con interruttore 0-I
- Tubo flessibile cromato
- Porta lampada in rame cromato
- Disponibile con lampada rossa o bianca da 250 watt

TABLE LAMP

- Stainless steel footplate with 0-I switch
- Chrome plated flexible tube
- Lamp holder made of chromed copper
- Available with red or white 250 watt lamp

- Struttura in acciaio inox
- I modelli SA70 e SA60M hanno le resistenze corazzate, mentre il modello SA40 ha tubi al quarzo che garantiscono un utilizzo immediato
- I modelli SA40 e SA60M hanno il regolatore di potenza

- Stainless steel body
- The models SA70 and SA60M have armoured elements, while the model SA40 has quartz tubes that guarantee an immediate use
- The models SA40 and SA60M have the power regulator

MODELLO MODEL	PREZZO PRICE	POTENZA WATT POWER WATT	ALIMENTAZIONE POWER SUPPLY	DIMENSIONI mm DIMENSIONS mm	ALTEZZA UTILE mm USEFUL HEIGHT mm	PESO NETTO Kg NET WEIGHT Kg	PESO LORDO Kg GROSS WEIGHT Kg	DIMENSIONI IMBALLO cm PACKING DIMENSIONS cm	MODELLO MODEL
SP1	€ 530,00	250	230/1N/50-60	340x580x760h	-	12,00	13,50	80x50x40h	SP1
LT25R - LT25W	€ 680,00	250	230/1N/50-60	Ø 175	-	11,00	13,00	30x30x100h	LT25R - LT25W
SA40	€ 560,00	2200	230/1N/50-60	560x360x390h	90 - 170	16,50	18,00	62x50x52h	SA40
SA70	€ 830,00	3200	230/1N/50-60	760x360x470h	120 - 220	21,10	23,10	93x47x47h	SA70
SA60M	€ 1.900,00	4000	400/3N/50-60	600x480x500h	100 ÷ 260	43,80	49,80	67x63x67h	SA60M



- Struttura in acciaio inox.
- Tubi al quarzo.
- Timer 0-15 minuti.
- Pinzette incluse per i modelli TS3 e TS6.
- Griglia inclusa nel modello TS42.
- Il modello TS42 ha due regolatori di potenza.

- *Stainless steel body.*
- *Quartz tubes.*
- *Timer 0-15 minutes.*
- *Pincers included for models TS3 and TS6.*
- *Grid included for model TS42.*
- *The model TS42 has two power regulators.*



- Struttura in acciaio inox
- Piano di cottura in acciaio liscio o rigato
- Termostato di lavoro 0-300 °C
- Cassetto frontale raccolta residui
- Regolazione indipendente nelle versioni FT2 e FT3

- *Stainless steel body*
- *Cooking surface in steel smooth or grooved*
- *Work thermostat 0-300 °C*
- *Fat collection front drawer*
- *Independent regulation in the FT2 and FT3 versions*

MODELLO MODEL	PREZZO PRICE	POTENZA WATT POWER WATT	ALIMENTAZIONE POWER SUPPLY	DIMENSIONI mm DIMENSIONS mm	ALTEZZA UTILE mm USEFUL HEIGHT mm	DIMENSIONI PIANO COTTURA mm COOKING SURFACE DIMENSIONS mm	PESO NETTO Kg NET WEIGHT Kg	PESO LORDO Kg GROSS WEIGHT Kg	DIMENSIONI IMBALLO cm PACKING DIMENSIONS cm	MODELLO MODEL
TS3	€ 300,00	2000	230/1N/50-60	440x240x250h	80	-	6,50	7,50	53x32x35h	TS3
TS6	€ 420,00	3000	230/1N/50-60	440x240x380h	2 x 80	-	8,60	9,70	53x32x46h	TS6
TS42	€ 710,00	2800	230/1N/50-60	710x340x290h	40 / 80	-	14,50	16,50	80x47x51h	TS42
FT1L	€ 700,00	3000	230/1N/50-60	400x500x200h	-	395x400x8h	20,50	22,50	60x45x28h	FT1L
FT1R	€ 840,00	3000	230/1N/50-60	400x500x200h	-	395x400x8h	22,80	24,80	60x45x28h	FT1R
FT2L	€ 1.050,00	6000	400/3N/50-60	600x500x200h	-	595x400x8h	28,20	32,20	70x54x38h	FT2L
FT2R	€ 1.210,00	6000	400/3N/50-60	600x500x200h	-	595x400x8h	31,00	35,00	70x54x38h	FT2R
FT2M	€ 1.120,00	6000	400/3N/50-60	600x500x200h	-	595x400x8h	29,50	33,50	70x54x38h	FT2M
FT3L	€ 1.350,00	9000	400/3N/50-60	840x500x200h	-	835x400x8h	34,70	42,50	90x60x41h	FT3L
FT3M	€ 1.600,00	9000	400/3N/50-60	840x500x200h	-	835x400x8h	36,00	44,00	90x60x41h	FT3M

FTG1L



FTG2L



CP40



CP20



- Struttura in acciaio inox.
- Piano di cottura in acciaio liscio o rigato ed estraibile per la manutenzione.
- Accensione con piezoelettrico.
- Cassetto frontale raccolta residui.
- Regolazione indipendente nella versione doppia.
- Predisposti a GPL (kit metano incluso).

- *Stainless steel body.*
- *Cooking surface in or grooved steel smooth and removable for maintenance.*
- *Piezo electric ignition.*
- *Fat collection front drawer.*
- *Independent regulation in the double version.*
- *Ready for LPG (kit for natural gas included).*

- Struttura in acciaio inox.
- Piastra di cottura in ghisa.
- Sei livelli di potenza.
- Limitatore di potenza di sicurezza.
- Modello CP40 con regolatori di potenza, separati.

- *Stainless steel structure.*
- *Cast iron cooking plate.*
- *Six power levels.*
- *Safety power limiter.*
- *CP40 model with separate power regulators.*

MODELLO MODEL	PREZZO PRICE	POTENZA WATT POWER WATT	ALIMENTAZIONE POWER SUPPLY	CONSUMO METANO m3/h NATURAL GAS CONSUMPTION m3/h	CONSUMO GPL Kg/h LPG CONSUMPTION Kg/h	DIMENSIONI mm DIMENSIONS mm	DIMENSIONI PIANO COTTURA mm COOKING SURFACE DIMENSIONS mm	PESO NETTO Kg NET WEIGHT Kg	PESO LORDO Kg GROSS WEIGHT Kg	DIMENSIONI IMBALLO cm PACKING DIMENSIONS cm	MODELLO MODEL
FTG1L	€ 720,00	3000	GAS	G20=0,32 / G25=0,37	G30-G31=0,25	330x450x275h	325x400x8h	14,80	16,80	60x45x28h	FTG1L
FTG2L	€ 1.290,00	6000	GAS	G20=0,64 / G25=0,74	G30-G31=0,50	600x450x275h	585x400x8h	26,80	30,80	70x54x38h	FTG2L
CP20	€ 430,00	2000	230/1N/50-60	-	-	300x400x160h	Ø 220	5,40	6,90	53x41x26h	CP20
CP40	€ 690,00	2000+2000	400/3N/50-60	-	-	600x400x160h	Ø 220 + 220	10,50	12,00	68x55x22h	CP40



CR35DE



CR35E

- Struttura in acciaio inox.
- Piano di cottura rigato in ghisa.
- Termostato di lavoro 0-300 °C.
- Interruttore I-O.

- *Stainless steel body.*
- *Grooved cast iron cooking surface.*
- *Work thermostat 0-300 °C.*
- *I-O switch.*



CC11



CC10

CC11

- Struttura in acciaio inox AISI304.
- Vasca, cestelli, piano appoggio cestelli e griglia di fondo in AISI316.
- Termostato 0-110°C.
- Interruttore 0-I.
- Rubinetto di scarico.
- Dotazione di serie: 1 cestello 27,5x15x20h cm e 2 cestelli 12,5x12,5x20h cm.

CC10

- Struttura in acciaio inox. Vasca, cestelli e griglia di fondo in acciaio inox AISI316.
- Termostato 0-110°C.
- Interruttore 0-I.
- Rubinetto di scarico.
- Dotazione di serie: 1 cestello da 27,5x15x20h cm e 2 cestelli 12,5x12,5x20h cm.

CC11

- *Structure in stainless steel AISI304.*
- *Basin, baskets, support surface for baskets and ground grid in AISI316.*
- *Thermostat 0-110°C.*
- *Switch 0-I.*
- *Water drain faucet.*
- *Standard equipment: 1 basket 27,5x15x20h cm and 2 baskets 12,5x12,5x20h cm.*

CC10

- *Stainless steel structure. Basin, baskets and ground grid in AISI316 stainless steel.*
- *Thermostat 0-110°C.*
- *Switch 0-I.*
- *Water drain faucet.*
- *Standard equipment: 1 basket 27,5x15x20h cm and 2 baskets 12,5x12,5x20h cm.*

MODELLO MODEL	PREZZO PRICE	POTENZA WATT POWER WATT	ALIMENTAZIONE POWER SUPPLY	DIMENSIONI mm DIMENSIONS mm		CAPACITÀ ACQUA l. WATER CAPACITY lt.	DIMENSIONI PIANO COTTURA mm COOKING SURFACE DIMENSIONS mm	PESO NETTO Kg NET WEIGHT Kg	PESO LORDO Kg GROSS WEIGHT Kg	DIMENSIONI IMBALLO cm PACKING DIMENSIONS cm	MODELLO MODEL
CR35E	€ 660,00	2400	230/1N/50-60	370x450x170h		-	Ø 350	14,00	16,00	40x52x26h	CR35E
CR35DE	€ 1.150,00	2400 + 2400	400/3N/50-60	740x450x170h		-	Ø 350 + 350	28,00	31,00	80x65x37h	CR35DE
CC11	€ 1.250,00	3500	230/1N/50-60	400x700x340h		25	-	13,50	15,00	50x80x50h	CC11
CC10	€ 860,00	3500	230/1N/50-60	340x600x300h		25	-	10,50	12,00	67x40x37h	CC10



Bagnomaria GN1/1 Bain Marie GN1/1



Cuociuovo Egg cooker



BM116

BM121



BM216

BM221



BM116R

BM121R



BM216R

BM221R



EG6

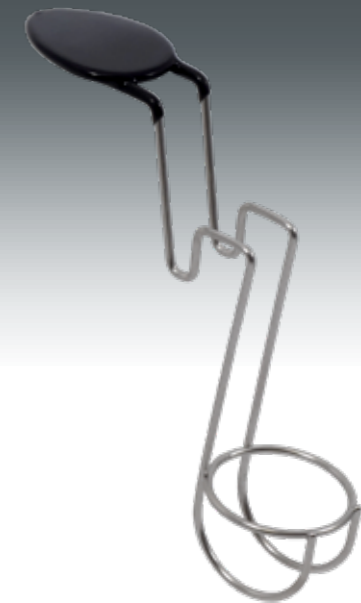

- Struttura in acciaio inox.
- Termostato di lavoro 0-90°C.
- Temperature differenziate nei modelli doppi.
- Il modello R è dotato di rubinetto di scarico.
- Tutti i modelli sono dotati di piastra riscaldante che garantisce un miglior rendimento e non si brucia in caso di mancanza di acqua.

- *Stainless steel body.*
- *Work thermostat 0-90°C.*
- *Separate temperatures in the double models.*
- *The model R is equipped with a faucet.*
- *All models are equipped with heating plate which guarantees better performance and does not burn in case of water shortage.*

- Cuociuovo con struttura in acciaio inox.
- Termostato di lavoro 0-110 °C.
- Termostato di sicurezza.
- Resistenza e vasca completamente removibili per la pulizia.
- Vasca, resistenza e portauovo in acciaio inox AISI 304.
- 6 portauovo e coperchio inclusi.

- *Egg cooker with stainless steel structure.*
- *Work thermostat 0-110 °C.*
- *Safety thermostat.*
- *Heating element and tank completely removable for cleaning.*
- *Bowl, heating element and egg holder in AISI 304 stainless steel.*
- *6 egg holders and lid included.*

MODELLO MODEL	PREZZO PRICE	POTENZA WATT POWER WATT	ALIMENTAZIONE POWER SUPPLY	DIMENSIONI mm DIMENSIONS mm	DIMENSIONI VASCA mm TANK DIMENSIONS mm	PROFONDITÀ VASCA mm BOWL DEPTH mm	PESO NETTO Kg NET WEIGHT Kg	PESO LORDO Kg GROSS WEIGHT Kg	DIMENSIONI IMBALLO cm PACKING DIMENSIONS cm	MODELLO MODEL
BM116	€ 350,00	1000	230/1N/50-60	340x540x250h	-	160 (GN 1/1 h 150mm max.)	7,20	8,20	40x63x37h	BM116
BM116R	€ 360,00	1000	230/1N/50-60	340x540x250h	-	160 (GN 1/1 h 150mm max.)	7,60	8,60	40x63x37h	BM116R
BM216	€ 500,00	1000 + 1000	230/1N/50-60	690x540x250h	-	160 (GN 1/1 h 150mm max.)	15,00	16,50	80x63x37h	BM216
BM216R	€ 610,00	1000 + 1000	230/1N/50-60	690x540x250h	-	160 (GN 1/1 h 150mm max.)	15,80	17,30	80x63x37h	BM216R
BM121	€ 440,00	1000	230/1N/50-60	340x540x300h	-	210 (GN 1/1 h 200mm max.)	7,70	8,70	40x63x37h	BM121
BM121R	€ 480,00	1000	230/1N/50-60	340x540x300h	-	210 (GN 1/1 h 200mm max.)	8,10	9,10	40x63x37h	BM121R
BM221	€ 710,00	1000 + 1000	230/1N/50-60	690x540x300h	-	210 (GN 1/1 h 200mm max.)	15,50	17,00	80x63x37h	BM221
BM221R	€ 820,00	1000 + 1000	230/1N/50-60	690x540x300h	-	210 (GN 1/1 h 200mm max.)	16,30	17,80	80x63x37h	BM221R
EG6	€ 520,00	2000	230/1N/50-60	245x430x310h	320x154x165h - 4 lt	-	4,5	5,2	50x27x34h	EG6



Macchine per Hot Dog

- Struttura in acciaio inox
- Termostato di lavoro 0-90°C

Cuoci e Scalda Würstel

- Struttura in acciaio inox
- Griglia interna inox forata
- Termostato di lavoro 0-110°C
- Temperature differenziate e rubinetto di scarico per SW20

Hot Dog Machines

- Stainless steel body
- Work thermostat 0-90°C

Sausage Cooker and Warmer

- Stainless steel body
- Internal perforated stainless steel grid
- Work thermostat 0-110°C
- Separate temperatures and drain tap for SW20

MODELLO MODEL	PREZZO PRICE	POTENZA WATT POWER WATT	ALIMENTAZIONE POWER SUPPLY	DIMENSIONI mm DIMENSIONS mm		DIMENSIONI VASCA mm TANK DIMENSIONS mm	PESO NETTO Kg NET WEIGHT Kg	PESO LORDO Kg GROSS WEIGHT Kg	DIMENSIONI IMBALLO cm PACKING DIMENSIONS cm	MODELLO MODEL
SHS	€ 460,00	800	230/1N/50-60	280x270x400h		-	5,20	6,20	50x40x40h	SHS
SH3	€ 620,00	800	230/1N/50-60	420x300x400h		-	7,50	8,50	50x40x40h	SH3
SH4	€ 670,00	800	230/1N/50-60	420x300x400h		-	7,70	8,70	50x40x40h	SH4
SW10	€ 340,00	1000	230/1N/50-60	280x350x290h		238x300x170h	5,30	6,60	53x32x35h	SW10
SW20	€ 600,00	2000	230/1N/50-60	560x350x290h		2 x 238x300x170h	11,40	12,90	62x60x40h	SW20



PA111S PA211S PA311S PA411S



RESISTENZA CON SUPPORTO
IN SILICONE ADESIVO FLESSIBILE
HEATING ELEMENT WITH ADHESIVE
FLEXIBLE SILICONE SUPPORT



PI50



PV50

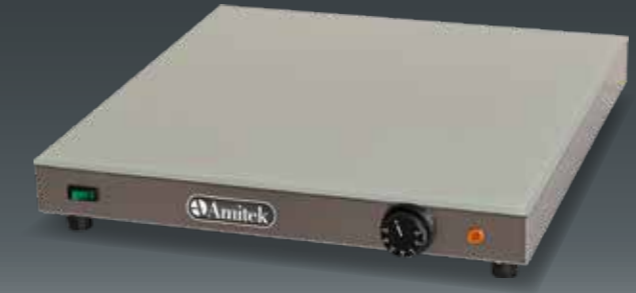

PV100

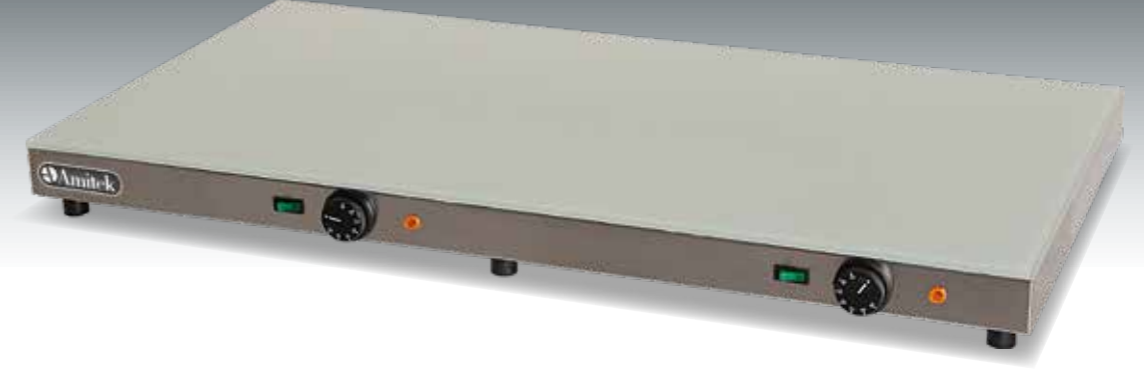

PI100



Modelli PA_S e PI

- Struttura e piano in acciaio inox.
- Termostato di lavoro 0-90 °C.

Modelli PV

- Struttura in acciaio inox.
- Piano in vetro temperato.
- Termostato di lavoro 0-90°C.

PA_S Models and PI

- Stainless steel structure and warming surface.
- Work thermostat 0-90 °C.

PV models

- Stainless steel body.
- Tempered glass surface.
- Work thermostat 0-90°C.

MODELLO MODEL	PREZZO PRICE	POTENZA WATT POWER WATT	ALIMENTAZIONE POWER SUPPLY	DIMENSIONI mm DIMENSIONS mm		PESO NETTO Kg NET WEIGHT Kg	PESO LORDO Kg GROSS WEIGHT Kg	DIMENSIONI IMBALLO cm PACKING DIMENSIONS cm	MODELLO MODEL
PA111S (1 x GN 1/1)	€ 280,00	400	230/1N/50-60	330x530x65h		4,00	5,00	60x60x15h	PA111S (1 x GN 1/1)
PA211S (2 x GN 1/1)	€ 410,00	800	230/1N/50-60	660x530x65h		7,00	8,00	80x60x15h	PA211S (2 x GN 1/1)
PA311S (3 x GN 1/1)	€ 560,00	1200	230/1N/50-60	990x530x65h		11,00	13,00	110x60x15h	PA311S (3 x GN 1/1)
PA411S (4 x GN 1/1)	€ 690,00	1600	230/1N/50-60	1320x530x65h		14,00	16,00	149x60x15h	PA411S (4 x GN 1/1)
PI50	€ 320,00	600	230/1N/50-60	500x500x70h		5,50	6,50	60x60x15h	PI50
PI100	€ 590,00	1200	230/1N/50-60	1000x500x70h		11,00	13,00	111x60x15h	PI100
PV50	€ 390,00	600	230/1N/50-60	500x500x70h		7,10	8,10	60x60x15h	PV50
PV100	€ 710,00	1200	230/1N/50-60	1000x500x70h		14,00	16,00	110x60x15h	PV100



FG650



FG11



FG65



- Struttura in acciaio inox.
- Bruciatore rimovibile.
- Predisposto a GPL (kit metano incluso).

- *Stainless steel body.*
- *Removable burner.*
- *Ready for LPG (included kit for natural gas).*

MODELLO MODEL	PREZZO PRICE	POTENZA WATT POWER WATT	ALIMENTAZIONE POWER SUPPLY	CONSUMO METANO m3/h NATURAL GAS CONSUMPTION m3/h	CONSUMO GPL Kg/h LPG CONSUMPTION Kg/h	DIMENSIONI mm DIMENSIONS mm	PESO NETTO Kg NET WEIGHT Kg	PESO LORDO Kg GROSS WEIGHT Kg	DIMENSIONI IMBALLO cm PACKING DIMENSIONS cm	MODELLO MODEL
FG65	€ 790,00	6500	GAS	G20 = 0,68	G30 = 0,52	340x490x210h	13,00	14,00	41x53x25h	FG65
FG650	€ 1.240,00	6500 + 6500	GAS	G20 = 1,37	G30 = 1,17	680x490x210h	23,50	26,00	80x51x42h	FG650
FG11	€ 990,00	10000	GAS	G20 = 1,06	G30 = 0,79	605x605x460h	21,40	23,40	70x70x55h	FG11



- Struttura in acciaio inox.
- Termostato 0 ÷ 90 °C.
- Pareti e porte coibentate per una minore dispersione del calore.
- Resistenze a "L" che garantiscono una miglior performance di riscaldamento.

- *Stainless steel structure.*
- *Thermostat 0 ÷ 90 °C.*
- *Insulated walls and doors for less heat dispersion.*
- *"L" shaped heating elements guarantees a better heating performance.*

MODELLO MODEL	PREZZO PRICE	POTENZA WATT POWER WATT	ALIMENTAZIONE POWER SUPPLY	NUMERO GRIGLIE SHELVES NO.	DIMENSIONI INTERNE mm INTERNAL DIMENSIONS mm	DIMENSIONI mm DIMENSIONS mm	PESO NETTO Kg NET WEIGHT Kg	PESO LORDO Kg GROSS WEIGHT Kg	DIMENSIONI IMBALLO cm PACKING DIMENSIONS cm	MODELLO MODEL
SPA30	€ 700,00	400	230/1N/50-60	2	336x370x369h	396x402x555h	17	18	61x49x53h	SPA30
SPA60	€ 870,00	750	230/1N/50-60	3	336x370x733h	396x402x865h	25	27	50x50x93h	SPA60
SPA120	€ 1.220,00	1500	230/1N/50-60	3	636x370x733h	697x402x865h	38	42	91x80x50h	SPA120



AWM40



AWD40



AWM100



AWD100



AWM60



AWD60



- Struttura interna ed esterna in acciaio inox.
- Predisposti per teglie GN1/1 e 60x40 cm.
- Interasse teglie 75 mm.
- Modelli "AWM" con comandi analogici. Modelli "AWD" con pannello comandi digitale programmabile.
- Camera di cottura a tenuta stagna e con angoli arrotondati.
- Inversione automatica del senso di rotazione della ventilazione.
- Illuminazione interna.
- Porta a doppio vetro con apertura a libro per facilitare la pulizia.

- Guarnizione porta facilmente estraibile.
- Temperatura di cottura 50 - 270 °C.
- Resistenze in acciaio inox Incoloy® 800.
- Isolamento termico della camera di cottura in fibra ceramica.
- Modalità di cottura: Convezione / convezione con umidificazione.
- Quantità di umidità regolabile.
- Allaccio idrico 3/4" (per umidificazione).

- Stainless steel internal and external structure.
- Suitable for GN1/1 and 60x40 cm trays.
- Trays interaxis 75 mm.
- "AWM" models with analog control. "AWD" models with programmable digital control panel.
- Watertight cooking chamber with internal rounded edges.
- Automatic inversion of the ventilation rotation direction.
- Internal light.
- Double glass door with book like opening for easy cleaning.

- Easy removable door gasket.
- Cooking temperature 50 - 270 °C.
- Heating elements in Incoloy® 800 stainless steel.
- Thermal insulation of the cooking chamber in ceramic fiber.
- Cooking modes: Convection / convection with humidification.
- Adjustable humidity quantity.
- 3/4" water inlet connection (for steam humidification).

MODELLO MODEL	PREZZO PRICE	POTENZA WATT POWER WATT	ALIMENTAZIONE POWER SUPPLY	CAPACITÀ TEGLIE TRAYS CAPACITY	DIMENSIONI mm DIMENSIONS mm	PESO NETTO Kg NET WEIGHT Kg	PESO LORDO Kg GROSS WEIGHT Kg	DIMENSIONI IMBALLO cm PACKING DIMENSIONS cm	MODELLO MODEL
AWM40	€ 2.760,00	6500	400/3N/50-60	4 GN1/1 - 60x40	865x735x565h	57	66	90x77x76h	AWM40
AWM60	€ 3.380,00	7900	400/3N/50-60	6 GN1/1 - 60x40	865x775x715h	81	90	91x82x91h	AWM60
AWM100	€ 4.140,00	11800	400/3N/50-60	10 GN1/1 - 60x40	865x775x1015h	106	116	91x82x121h	AWM100
AWD40	€ 2.970,00	6500	400/3N/50-60	4 GN1/1 - 60x40	865x735x565h	57	66	90x77x76h	AWD40
AWD60	€ 3.550,00	7900	400/3N/50-60	6 GN1/1 - 60x40	865x775x715h	81	90	91x82x91h	AWD60
AWD100	€ 4.340,00	11800	400/3N/50-60	10 GN1/1 - 60x40	865x775x1015h	106	116	91x82x121h	AWD100



KB4



KB44



- Struttura frontale in acciaio inox.
- Scocca in lamiera verniciata nera.
- Piano di cottura refrattario con spessore da 14 mm.
- Termostato 0-500 °C.
- Pirometro.

- Illuminazione interna.
- Porta con ampio vetro.
- Isolamento in lana di roccia ad alta densità.
- Resistenze corazzate.

- *Front structure in stainless steel.*
- *Outer shell in black painted metal sheet.*
- *Baking surface in refractory stone of 14 mm thickness.*
- *Thermostat 0-500 °C.*
- *Temperature gauge.*

- *Inner light.*
- *Door with wide glass.*
- *High-density rock wool insulation.*
- *Sheathed heating elements.*

MODELLO MODEL	PREZZO PRICE	POTENZA WATT POWER WATT	ALIMENTAZIONE POWER SUPPLY	DIMENSIONI mm DIMENSIONS mm	DIMENSIONE CAMERA DI COTTURA mm BAKING CHAMBER DIMENSIONS mm	PESO NETTO Kg NET WEIGHT Kg	PESO LORDO Kg GROSS WEIGHT Kg	DIMENSIONI IMBALLO cm PACKING DIMENSIONS cm	MODELLO MODEL
KB4	€ 1.490,00	4800	230/1N/50-60 or 400/3N/50-60	930x840x335h	700x700x140h	50	68	97x100x47h	KB4
KB44	€ 2.210,00	9600	230/1N/50-60 or 400/3N/50-60	930x840x545h	700x700x140h	91	107	97x100x70h	KB44



Forni elettrici pizzeria KS e KL Electric pizza ovens KS and KL



KS44

KS66

KL4

KL6

KL44

KL66

KS4

KS6



- Struttura frontale in acciaio inox.
- Piano di cottura refrattario 18mm.
- Termostato 0-500°C.
- Pirometro.
- Illuminazione interna.
- Ampio vetro.

- Front structure in stainless steel.
- Baking surface in refractory stone 18mm.
- Thermostat 0-500°C.
- Temperature gauge.
- Inner light.
- Wide glass.

MODELLO MODEL	PREZZO PRICE	POTENZA WATT POWER WATT	ALIMENTAZIONE POWER SUPPLY	DIMENSIONI mm DIMENSIONS mm	DIMENSIONE CAMERA COTTURA mm BAKING CHAMBER DIMENSIONS mm	PESO NETTO Kg NET WEIGHT Kg	PESO LORDO Kg GROSS WEIGHT Kg	DIMENSIONI IMBALLO cm PACKING DIMENSIONS cm	MODELLO MODEL
KS4	€ 1.620,00	4200	230/1N/50-60 or 400/3N/50-60	900x735x420h	610x610x140h	67,00	87,00	100x96x57h	KS4
KS44	€ 2.390,00	8400	230/1N/50-60 or 400/3N/50-60	900x735x750h	610x610x140h	115,00	140,00	100x96x92h	KS44
KS6	€ 1.860,00	7200	230/1N/50-60 or 400/3N/50-60	900x1020x420h	610x910x140h	86,00	111,00	121x96x57h	KS6
KS66	€ 2.890,00	14400	230/1N/50-60 or 400/3N/50-60	900x1020x750h	610x910x140h	151,00	180,00	121x96x92h	KS66
KL4	€ 1.820,00	6000	230/1N/50-60 or 400/3N/50-60	1010x850x420h	720x720x140h	85,00	108,00	109x104x57h	KL4
KL44	€ 2.800,00	12000	230/1N/50-60 or 400/3N/50-60	1010x850x750h	720x720x140h	146,00	173,00	109x104x92h	KL44
KL6	€ 2.210,00	9000	230/1N/50-60 or 400/3N/50-60	1010x1210x420h	720x1080x140h	116,00	143,00	109x140x57h	KL6
KL66	€ 3.620,00	18000	230/1N/50-60 or 400/3N/50-60	1010x1210x750h	720x1080x140h	200,00	231,00	109x140x92h	KL66



Forno elettrico pizzeria KT Electric pizza ovens KT



KT44 KT66
KT66R KT99



- Struttura frontale in acciaio inox
- Camera di cottura interamente in refrattario 18mm
- Termostato 0-500°C
- Pirometro
- Illuminazione interna
- Ampio vetro

- Front structure in stainless steel
- Baking chamber entirely in refractory stone 18mm
- Thermostat 0-500°C
- Temperature gauge
- Inner light
- Wide glass

MODELLO MODEL	PREZZO PRICE	POTENZA WATT POWER WATT	ALIMENTAZIONE POWER SUPPLY	DIMENSIONI mm DIMENSIONS mm	DIMENSIONE CAMERA COTTURA mm BAKING CHAMBER DIMENSIONS mm	PESO NETTO Kg NET WEIGHT Kg	PESO LORDO Kg GROSS WEIGHT Kg	DIMENSIONI IMBALLO cm PACKING DIMENSIONS cm
KT4	€ 2.640,00	6000	400/3N/50-60 or 230/1N/50-60	1010x850x420h	720x720x140h	130,00	152,00	109x104x57h
KT44	€ 4.320,00	12000		1010x850x750h	720x720x140h	225,00	252,00	109x104x92h
KT6	€ 3.090,00	9000		1010x1210x420h	720x1080x140h	190,00	217,00	109x140x57h
KT66	€ 5.420,00	18000		1010x1210x750h	720x1080x140h	340,00	367,00	109x140x92h
KT6R	€ 3.470,00	9000		1370x850x420h	1080x720x140h	195,00	220,00	145x104x57h
KT66R	€ 6.240,00	18000		1370x850x750h	1080x720x140h	355,00	380,00	145x104x92h
KT9	€ 4.380,00	13200		1370x1210x420h	1080x1080x140h	220,00	270,00	145x140x57h
KT99	€ 8.110,00	26400		400/3N/50-60	1370x1210x750h	1080x1080x140h	455,00	475,00



Supporti per forni pizzeria Floor stand for pizza ovens



MODELLO MODEL	PREZZO PRICE	ADATTO AI MOD. SUITABLE FOR MOD.	DIMENSIONI mm DIMENSIONS mm	PESO NETTO Kg NET WEIGHT Kg	PESO LORDO Kg GROSS WEIGHT Kg	DIMENSIONI IMBALLO cm PACKING DIMENSIONS cm
KBP4	€ 450,00	KB4 - KB44	930x840x980h	29,00	30,00	100x89x13h
KSP4	€ 450,00	KS4	900x735x980h	30,00	31,00	91x75x13h
KSP44	€ 450,00	KS44	900x735x850h	30,00	31,00	91x75x13h
KSP6	€ 490,00	KS6	900x1020x980h	38,00	39,00	103x91x13h
KSP66	€ 490,00	KS66	900x1020x850h	38,00	39,00	103x91x13h
KLP-KTP4	€ 470,00	KL4 - KT4	1010x850x980h	39,00	40,00	102x86x13h
KLP-KTP44	€ 470,00	KL44 - KT44	1010x850x850h	39,00	40,00	102x86x13h
KLP-KTP6	€ 560,00	KL6 - KT6	1010x1210x980h	48,00	49,00	102x122x13h
KLP-KTP66	€ 560,00	KL66 - KT66	1010x1210x850h	48,00	49,00	102x122x13h
KTP6R	€ 590,00	KT6R	1370x850x980h	45,00	46,00	138x86x13h
KTP66R	€ 590,00	KT66R	1370x850x850h	45,00	46,00	138x86x13h
KTP9	€ 780,00	KT9	1370x1210x980h	63,00	64,00	138x122x13h
KTP99	€ 780,00	KT99	1370x1210x850h	63,00	64,00	138x122x13h



- Struttura frontale in acciaio inox
- Piano di cottura in refrattario da 14 mm per mod. KB e 17 mm per mod. KM
- Termostato 0-500°C

- Front structure in stainless steel
- Baking surface in refractory stone of 14 mm for mod. KB and 17 mm for mod. KM
- Thermostat 0-500°C

MODELLO MODEL	PREZZO PRICE	POTENZA WATT POWER WATT	ALIMENTAZIONE POWER SUPPLY	DIMENSIONI mm DIMENSIONS mm	DIMENSIONE CAMERA COTTURA mm BAKING CHAMBER DIMENSIONS mm	PESO NETTO Kg NET WEIGHT Kg	PESO LORDO Kg GROSS WEIGHT Kg	DIMENSIONI IMBALLO cm PACKING DIMENSIONS cm	MODELLO MODEL
KB1	€ 880,00	2200	230/1N/50-60	555x460x290h	405x405x110h	27,00	35,00	62x62x45h	KB1
KB2	€ 1.650,00	4400	230/1N/50-60 or 400/3N/50-60	555x460x530h	405x405x110h	55,00	63,00	62x62x69h	KB2
KM2	€ 1.690,00	6000	230/1N/50-60 or 400/3N/50-60	780x600x530h	500x500x110h	66,00	80,00	85x82x69h	KM2
KMP2	€ 450,00	-	-	780x600x980h	-	26,00	27,00	79x61x13h	KMP2



Forni a gas pizzeria KGS e KGL

Gas pizza ovens KGS and KGL



KG4S KG4L
KG6S KG6L
KG9S KG9L



KGP4S KGP4L
KGP6S KGP6L
KGP9S KGP9L



KGC15
KGC20



KGR15
KGR20



- Struttura frontale in acciaio inox.
- Piano di cottura in refrattario forato da 25mm.
- Termostato e pirometro digitale 0-450°C.
- Illuminazione interna.
- Ampio vetro.
- Accensione con piezoelettrico.
- Predisposti a metano (kit GPL incluso).
- Il raccordo KGR è necessario per sovrapporre due forni.
- Il camino KGC può essere utilizzato sia sul forno singolo sia su forni sovrapposti per migliorare la combustione.

- Front structure made of stainless steel.
- Baking surface with perforated refractory stone 25mm thick.
- Digital thermostat and temperature gauge 0-450°C.
- Inner light.
- Large vision glass.
- Piezo electric ignition.
- Ready for natural gas (supplied with kit for LPG).
- The connection KGR is necessary for stacking two ovens.
- The windproof KGC can be used either for a single oven or for stacked ovens to improve combustion.

MODELLO MODEL	ADATTO AI MOD. SUITABLE FOR MOD.	DIMENSIONI mm DIMENSIONS mm	PESO NETTO Kg NET WEIGHT Kg	PESO LORDO Kg GROSS WEIGHT Kg	DIMENSIONI IMBALLO cm PACKING DIMENSIONS cm	PREZZO PRICE
KGP4S	KG4S	1000x840x1000h	34,00	35,00	102x77x13h	€ 450,00
KGP6S	KG6S	1000x1140x1000h	42,00	43,00	116x141x13h	€ 530,00
KGP9S	KG9S	1300x1140x1000h	52,00	53,00	147x141x13h	€ 610,00
KGP4L	KG4L	1095x940x1000h	41,00	42,00	112x87x13h	€ 500,00
KGP6L	KG6L	1095x1300x1000h	52,00	53,00	112x130x13h	€ 560,00
KGP9L	KG9L	1455x1300x1000h	64,00	65,00	140x130x13h	€ 780,00
KGC15	-	310x310x500h	3,00	4,00	34x34x52h	€ 570,00
KGC20	-	400x400x640h	4,00	5,00	43x43x66h	€ 600,00
KGR15	-	310x200x690h	6,00	7,00	34x23x72h	€ 500,00
KGR20	-	310x200x690h	6,00	7,00	34x23x72h	€ 600,00

MODELLO MODEL	PREZZO PRICE	POTENZA WATT POWER WATT	ALIMENTAZIONE POWER SUPPLY	CONSUMO METANO m3/h NATURAL GAS CONSUMPTION m3/h	CONSUMO GPL Kg/h LPG CONSUMPTION Kg/h	DIMENSIONI mm DIMENSIONS mm	DIMENSIONE CAMERA COTTURA mm BAKING CHAMBER DIMENSIONS mm	PESO NETTO Kg NET WEIGHT Kg	PESO LORDO Kg GROSS WEIGHT Kg	DIMENSIONI IMBALLO cm PACKING DIMENSIONS cm	MODELLO MODEL
KG4S	€ 4.460,00	13900	GAS 230/1N/50-60	G20=1,47	G30-G31= 1,09	1000x840x470h	620x620x155h	113,00	130,00	106x103x64h	KG4S
KG6S	€ 5.310,00	18000	GAS 230/1N/50-60	G20=1,90	G30-G31 = 1,41	1000x1140x470h	620x920x155h	140,00	162,00	133x106x64h	KG6S
KG9S	€ 6.230,00	24500	GAS 230/1N/50-60	G20=2,60	G30-G31 = 1,92	1300x1140x470h	920x920x155h	180,00	200,00	138x131x64h	KG9S
KG4L	€ 5.090,00	17000	GAS 230/1N/50-60	G20=1,80	G30-G31 = 1,32	1095x940x470h	720x720x155h	140,00	160,00	116x113x64h	KG4L
KG6L	€ 5.930,00	22500	GAS 230/1N/50-60	G20=2,38	G30-G31 = 1,75	1095x1300x470h	720x1080x155h	174,00	200,00	116x141x64h	KG6L
KG9L	€ 7.580,00	30000	GAS 230/1N/50-60	G20=3,18	G30-G31 = 2,33	1455x1300x470h	1080x1080x155h	220,00	248,00	147x141x64h	KG9L



Stendipizza
Pizza dough rollers



SD32

SD42



SD42P



SD35M

- Struttura interamente in acciaio inox.
- Rulli realizzati in materiale plastico idoneo al contatto con gli alimenti.
- Regolazione spessore apertura rullo.
- Trasmissione a cinghia.
- Comando a pedale PSD opzionale (solo SD32-SD42-SD42P).

- Structure entirely made of stainless steels.
- Roller made of plastic material suitable for contact with food.
- Roller thickness aperture adjustment.
- Belt drive.
- PSD footswitch available as optional (SD32-SD42-SD42P only).

MODELLO MODEL	PREZZO PRICE	POTENZA WATT POWER WATT	ALIMENTAZIONE POWER SUPPLY	DIMENSIONI mm DIMENSIONS mm	PESO NETTO Kg NET WEIGHT Kg	PESO LORDO Kg GROSS WEIGHT Kg	DIMENSIONI IMBALLO cm PACKING DIMENSIONS cm
SD32	€ 1.390,00	370	230/1N/50-60	430x500x630h	26,00	30,00	51x67x53h
SD35M	€ 1.240,00	370	230/1N/50-60	500x400x450h	22,00	26,00	51x67x53h
SD42	€ 1.620,00	370	230/1N/50-60	530x530x730h	35,00	39,00	61x78x68h
SD42P	€ 1.640,00	370	230/1N/50-60	530x530x730h	35,00	39,00	61x78x68h

OPTIONAL PSD
solo per: SD32 - SD42 - SD42P
only for: SD32 - SD42 - SD42P



PSD	Comando a pedale (opzionale) per modelli SD32, SD42 e SD42P	Footswitch (optional) for SD32, SD42 and SD42P models	€ 120,00
-----	--	--	----------



Affettatrici a gravità SG

Gravity Slicers SG



BLOCCO PIATTO
VELA DI SERIE
STANDARD FENCE-PLATE
SAFETY LOCK

SG220P
CE PROFESSIONAL

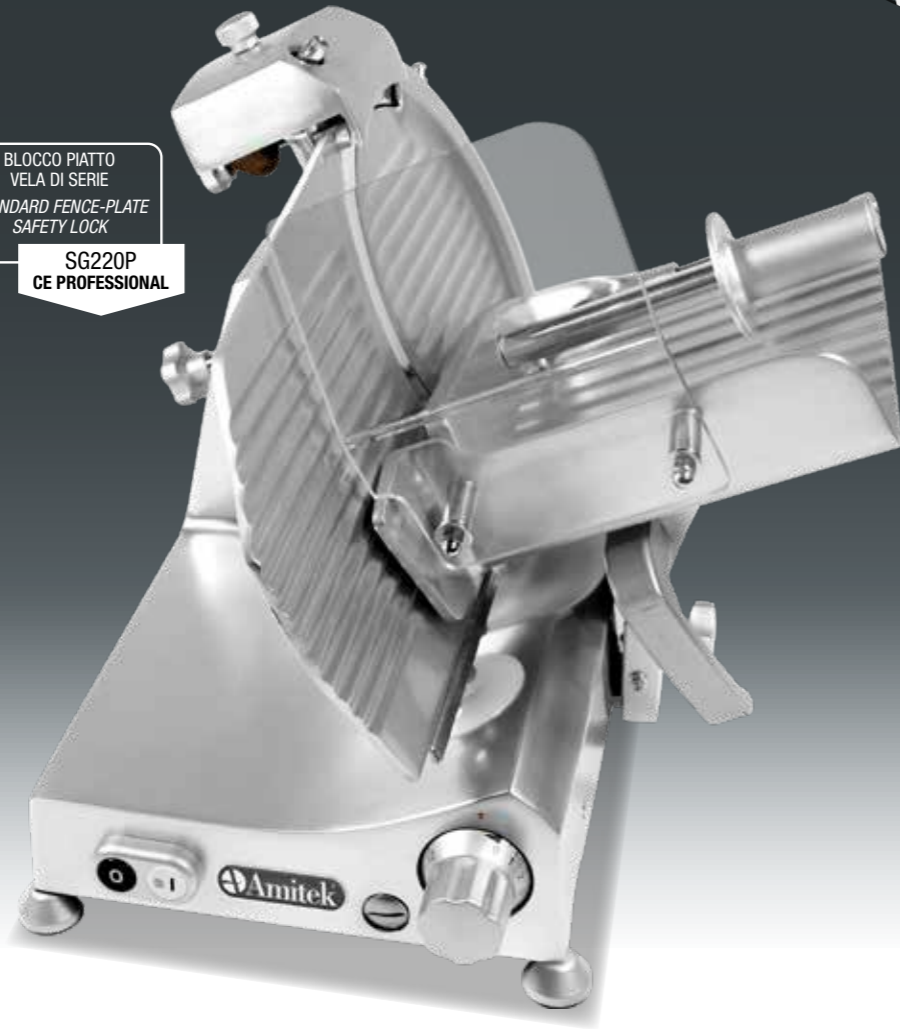

BLOCCO PIATTO
VELA DI SERIE
STANDARD FENCE-PLATE
SAFETY LOCK

SG350P
CE PROFESSIONAL



- Struttura in lega di alluminio con fusione in conchiglia.
- Superficie tutta lucidata e anodizzata.
- Regolazione taglio da 0 a 16mm.
- Affilatoio fisso superiore di serie e di facile utilizzo (tranne il modello SG195X che ha l'affilatoio staccato).
- Piatto montato su cuscinetti per maggiore scorrevolezza.

- Lama in acciaio cromato e temprato.
- Anello fisso intorno alla lama
- Blocco piatto-vela di serie sui modelli CE professionali (CE PRO)
- Motore ventilato su tutti i modelli tranne la SG195X
- Disponibili anche nella versione senza norme CE (EXTRA CE).

- Aluminium alloy with chilled casting structure.
- All surfaces polished and anodized.
- Slicing thickness adjustment from 0 to 16 mm.
- Upper fixed sharpener supplied as standard and easy to use (except model SG195X that has separated sharpener).
- Chromed and tempered steel blade.

- Food carriage mounted on ball bearings to ensure smooth gliding.
- Fixed protection ring around the blade
- Fence plate safety lock as standard on CE professional (CE PRO)
- Ventilated motor on all models except the SG195X
- Also available in version without CE norms (EXTRA CE).

MODELLO MODEL	PREZZO PRICE	POTENZA WATT POWER WATT	ALIMENTAZIONE POWER SUPPLY	Ø LAMA mm Ø BLADE mm	TAGLIO UTILE mm USEFUL CUT mm	RPM	DIMENSIONI INGOMBRO MAX mm MAX OVERALL DIMENSIONS mm	DISTANZA TRA PIEDINI mm DISTANCE BETWEEN THE FEET mm	PESO NETTO Kg NET WEIGHT Kg	PESO LORDO Kg GROSS WEIGHT Kg	DIMENSIONI IMBALLO cm PACKING DIMENSIONS cm	MODELLO MODEL
SG220P	€ 1.010,00	185	230/1N/50	220	190x160	300	405x580x340h	280x415	14,00	16,00	50x43x44h	SG220P
SG250P	€ 1.160,00	220	230/1N/50	250	220x190	300	425x620x370h	290x440	17,00	19,00	54x46x45h	SG250P
SG275P	€ 1.220,00	220	230/1N/50	275	220x210	300	440x620x390h	290x440	18,00	20,00	54x46x45h	SG275P
SG300RP	€ 1.420,00	230	230/1N/50 or 400/3/50	300	220x210	300	485x650x440h	290x440	20,00	24,00	64x52x49h	SG300RP
SG300P	€ 1.700,00	260	230/1N/50 or 400/3/50	300	260x220	300	495x650x440h	340x465	24,00	27,00	64x52x49h	SG300P
SG300LP	€ 1.860,00	260	230/1N/50 or 400/3/50	300	280x220	300	500x760x510h	340x490	25,00	29,00	70x63x52h	SG300LP
SG330P	€ 2.320,00	260	230/1N/50 or 400/3/50	330	260x235	280	550x770x465h	410x530	32,00	43,00	70x63x64h	SG330P
SG350P	€ 2.710,00	370	230/1N/50 or 400/3/50	350	310x260	260	585x890x480h	415x580	36,00	52,00	80x73x67h	SG350P
SG370P	€ 2.850,00	370	230/1N/50 or 400/3/50	370	310x275	260	585x890x480h	415x580	37,00	53,00	80x73x67h	SG370P

Affettatrici a gravità SG Gravity Slicers SG



SG220X
EXTRA CE
EXPORT



SG370X
EXTRA CE
EXPORT

MODELLO MODEL	PREZZO PRICE	POTENZA WATT POWER WATT	ALIMENTAZIONE POWER SUPPLY	Ø LAMA mm Ø BLADE mm	TAGLIO UTILE mm USEFUL CUT mm	RPM		DIMENSIONI INGOMBRO MAX mm MAX OVERALL DIMENSIONS mm	DISTANZA TRA PIEDINI mm DISTANCE BETWEEN THE FEET mm	PESO NETTO Kg NET WEIGHT Kg	PESO LORDO Kg GROSS WEIGHT Kg	DIMENSIONI IMBALLO cm PACKING DIMENSIONS cm	MODELLO MODEL
SG195X	€ 660,00	150	230/1N/50	195	140x140	300		360x520x315h	255x345	10,00	12,00	34x42x40h	SG195X
SG220X	€ 820,00	185	230/1N/50	220	190x160	300		405x580x340h	280x415	14,00	16,00	50x43x44h	SG220X
SG250RX	€ 880,00	185	230/1N/50	250	190x190	300		405x580x370h	280x415	15,00	17,00	54x46x45h	SG250RX
SG250X	€ 950,00	220	230/1N/50	250	220x190	300		425x620x370h	290x440	17,00	19,00	54x46x45h	SG250X
SG275X	€ 1.010,00	220	230/1N/50	275	220x210	300		440x620x390h	290x440	18,00	20,00	54x46x45h	SG275X
SG300RX	€ 1.220,00	230	230/1N/50 or 400/3/50	300	220x210	300		485x650x440h	290x440	20,00	24,00	64x52x49h	SG300RX
SG300X	€ 1.340,00	260	230/1N/50 or 400/3/50	300	260x220	300		495x650x440h	340x465	24,00	27,00	64x52x49h	SG300X
SG300LX	€ 1.550,00	260	230/1N/50 or 400/3/50	300	280x220	300		500x760x510h	340x490	25,00	29,00	70x63x52h	SG300LX
SG330X	€ 2.020,00	260	230/1N/50 or 400/3/50	330	260x235	280		550x770x465h	410x530	32,00	43,00	70x63x64h	SG330X
SG350X	€ 2.350,00	370	230/1N/50 or 400/3/50	350	310x260	260		585x890x480h	415x580	36,00	52,00	80x73x67h	SG350X
SG370X	€ 2.500,00	370	230/1N/50 or 400/3/50	370	310x275	260		585x890x480h	415x580	37,00	53,00	80x73x67h	SG370X

Affettatrici versione X: Extra CE - Export
Slicers version X: Without CE Norms - Export

Affettatrici versione X: Extra CE - Export
Slicers version X: Without CE Norms - Export



Affettatrici a volano

Volano slicers

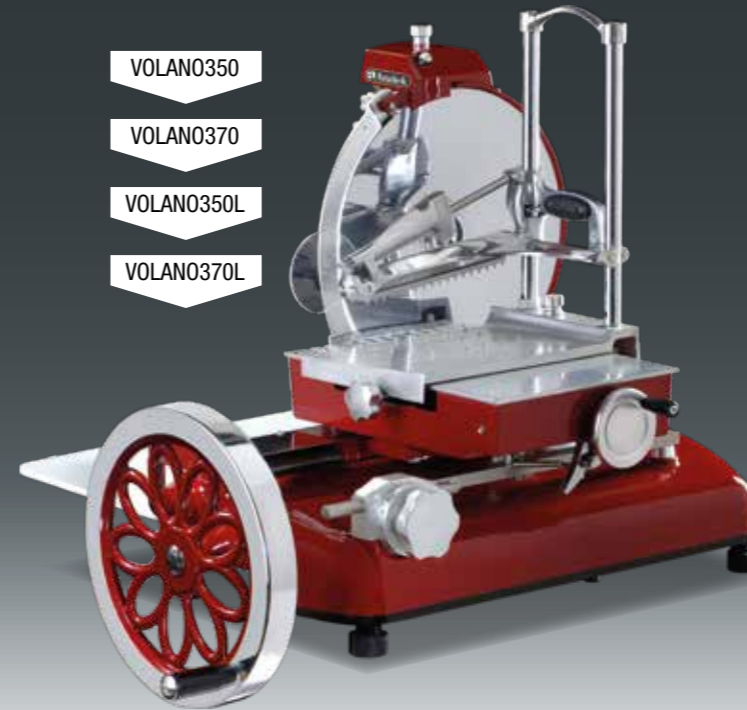

- Struttura pesante in lega di alluminio con fusione in conchiglia per garantire una durata nel tempo ed elevata affidabilità.
- Superficie verniciata a "fuoco" per ottenere una lucentezza ed un'igiene ottimali.
- Affilato superiore di serie e di facile utilizzo.
- Spessore di taglio da 0 a 2mm.
- Anello paralama fisso.
- Disponibile nella versione standard e nella versione LUSO "L" (con decori adesivi).
- La verniciatura in rosso bordò e nera sono standard.
- A richiesta si possono eseguire colori RAL con sovrapprezzo.

- Heavy structure with aluminum alloy with chilled casting to grant a long life and a good reliability.
- Fire painted surface to get a sheen and optimum hygiene.
- Upper sharpener standard and easy to use.
- Cutting thickness from 0 to 2mm.
- Fixed blade protecting ring.
- Available in standard version and in LUXURY version "L" (with decorative stickers).
- Standard painted in red or black.
- RAL colors available on request with additional price.

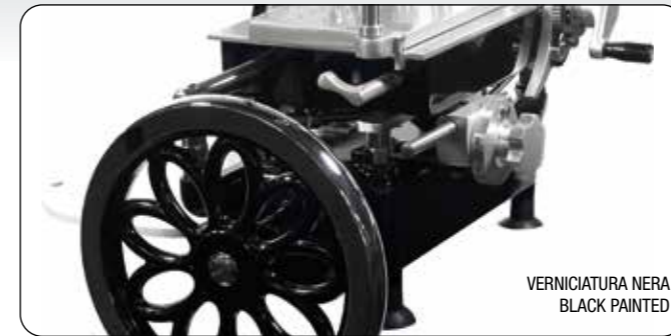

MODELLO MODEL	PREZZO PRICE	Ø LAMA mm Ø BLADE mm	TAGLIO UTILE mm USEFUL CUT mm	DIMENSIONI mm DIMENSIONS mm	DIMENSIONI PIANO DI APPOGGIO mm BOTTOM SURFACE DIMENSIONS mm	PESO NETTO Kg NET WEIGHT Kg	PESO LORDO Kg GROSS WEIGHT Kg	DIMENSIONI IMBALLO cm PACKING DIMENSIONS cm	MODELLO MODEL
VOLANO250	€ 5.000,00	250	185x150	520x680x510h	-	33,00	48,00	85x75x85h	VOLANO250
VOLANO250L	€ 5.600,00	250	185x150	520x680x510h	-	33,00	48,00	85x75x85h	VOLANO250L
VOLANO300	€ 5.500,00	300	230x190	600x720x740h	-	43,00	76,00	85x75x85h	VOLANO300
VOLANO300L	€ 6.000,00	300	230x190	600x720x740h	-	43,00	76,00	85x75x85h	VOLANO300L
VOLANO350	€ 9.000,00	350	270x240	710x870x800h	-	91,00	123,00	100x90x100h	VOLANO350
VOLANO350L	€ 9.600,00	350	270x240	710x870x800h	-	91,00	123,00	100x90x100h	VOLANO350L
VOLANO370	€ 9.300,00	370	270x250	710x870x800h	-	91,00	123,00	100x90x100h	VOLANO370
VOLANO370L	€ 9.900,00	370	270x250	710x870x800h	-	91,00	123,00	100x90x100h	VOLANO370L
CV250	€ 1.900,00	-	-	640x415x795h	325x415	44,30	61,30	80x74x96h	CV250
CV300	€ 1.900,00	-	-	640x500x795h	400x500	46,70	63,70	80x74x96h	CV300
CV350-370	€ 2.000,00	-	-	650x730x795h	450x700	53,00	71,00	80x74x103h	CV350-370



SG220T

SG250T

SG275T



SG300T

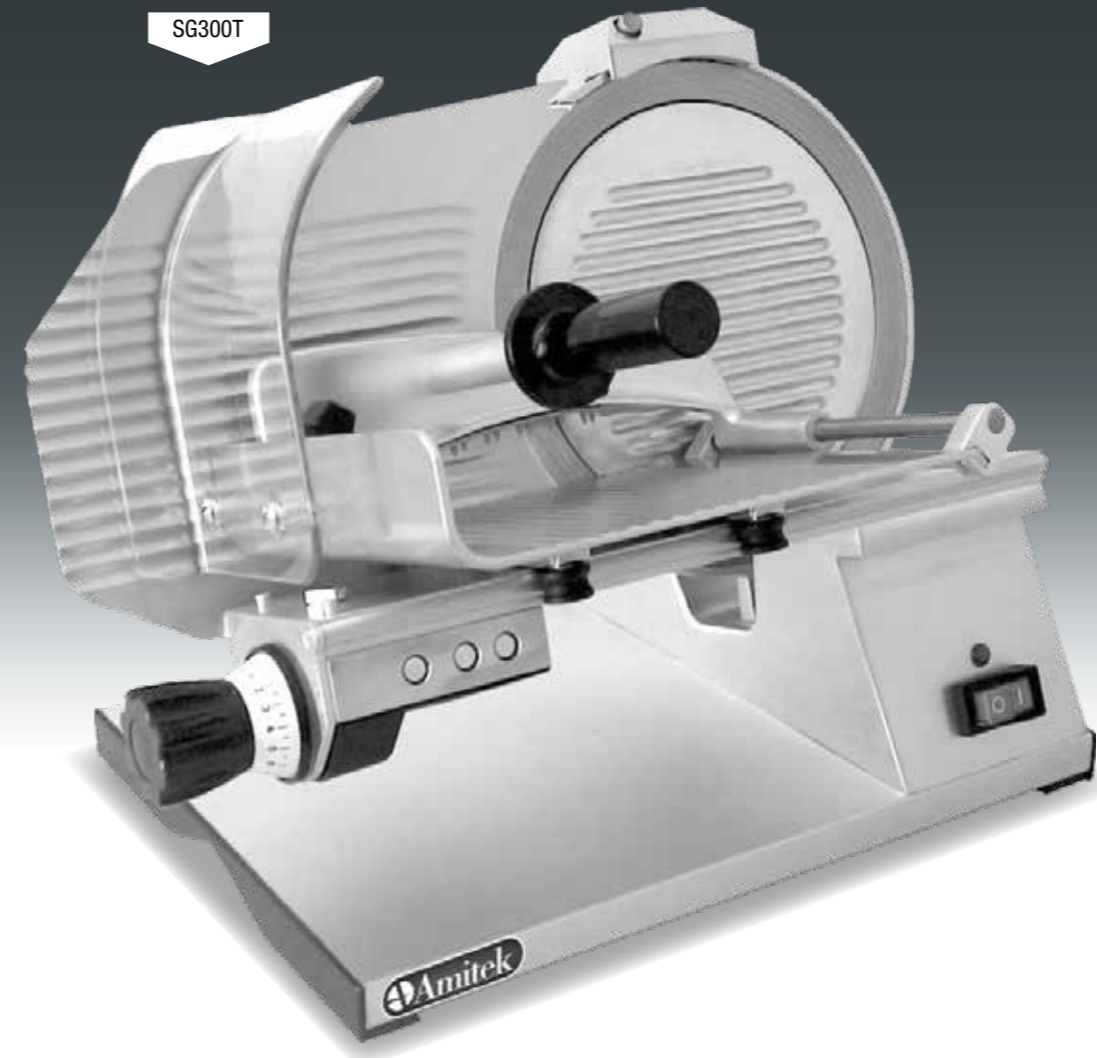

- Struttura in lega di alluminio.
- Superficie tutta lucidata e anodizzata.
- Trasmissione ad ingranaggio.
- Regolazione taglio da 0 a 16mm.
- Affilatoio fisso nella SG300T; nelle restanti affilatoio staccato.
- Piatto montato su 4 cuscinetti per maggiore scorrevolezza.
- Lama in acciaio cromato e temperato.

- Anello fisso inox intorno alla lama.
- Piatto removibile con blocco vela di serie.
- Motore ventilato con protezione termica.
- Disponibili solo nella versione CE professionale (CE PRO).

- Aluminium alloy structure.
- All surfaces polished and anodized.
- Geared transmission.
- Adjustable slicing from 0 to 16mm.
- Fixed sharpener in model SG300T; removable sharpener in the other models.
- Plate mounted on 4 ball bearings for an exceptionally

- smooth running.
- Chrome plated and tempered steel blade.
- Fixed protection stainless steel ring around the blade.
- Removable plate with safety lock as standard.
- Ventilated motor with thermal protection.
- Available only in CE professional version (CE PRO).

MODELLO MODEL	PREZZO PRICE	POTENZA WATT POWER WATT	ALIMENTAZIONE POWER SUPPLY	Ø LAMA mm Ø BLADE mm	TAGLIO UTILE mm USEFUL CUT mm	RPM		DIMENSIONI INGOMBRO MAX mm MAX OVERALL DIMENSIONS mm	DISTANZA TRA PIEDINI mm DISTANCE BETWEEN THE FEET mm	PESO NETTO Kg NET WEIGHT Kg	PESO LORDO Kg GROSS WEIGHT Kg	DIMENSIONI IMBALLO cm PACKING DIMENSIONS cm	MODELLO MODEL
SG220T CE PRO	€ 1.230,00	200	230/1N/50	220	195x155	243		380x490x370h	275x375	12,50	14,50	47x57x46h	SG220T CE PRO
SG250T CE PRO	€ 1.400,00	200	230/1N/50	250	230x175	243		425x525x380h	275x430	14,00	16,00	47x57x46h	SG250T CE PRO
SG275T CE PRO	€ 1.480,00	200	230/1N/50	275	230x180	243		425x535x405h	275x460	15,00	17,00	47x57x46h	SG275T CE PRO
SG300T CE PRO	€ 2.150,00	320	230/1N/50	300	265x210	207		480x640x515h	350x490	20,80	23,40	52x62x53h	SG300T CE PRO



Affettatrici verticali SV Vertical slicers SV

Affettatrici versione P: Norme CE professionali
Slicers version P: Professional CE Norms

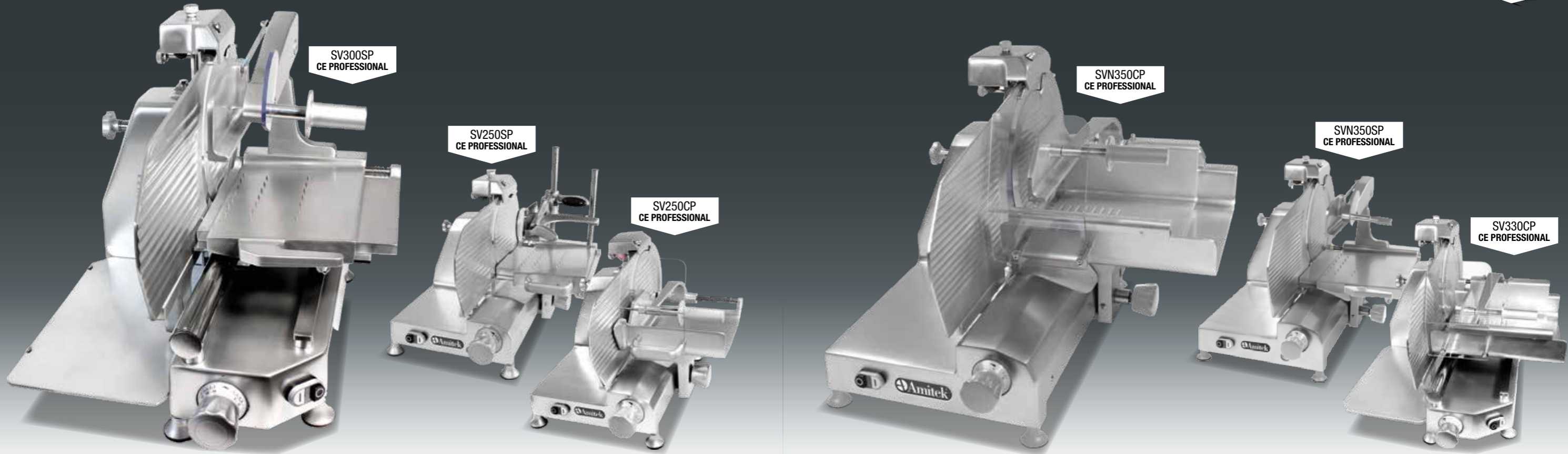

- Struttura in lega di alluminio con fusione in conchiglia.
- Superficie tutta lucidata e anodizzata.
- Regolazione taglio da 0 a 16mm di alta precisione.
- Affilatoio fisso superiore di serie e di facile utilizzo.
- Piatto montato su cuscinetti per maggiore scorrevolezza.
- Lama in acciaio cromato e temprato.

- Anello fisso intorno alla lama.
- Blocco piatto-vela di serie.
- Motore ventilato su tutti i modelli.
- Disponibili nella versione salumi (S) e nella versione col piatto carne (C).

- Aluminium alloy with chilled casting structure.
- All surfaces polished and anodized.
- High precision slicing thickness adjustment from 0 to 16 mm.
- Upper fixed sharpener supplied as standard and easy to use.
- Food carriage mounted on ball bearings to ensure smooth gliding.

- Chromed and tempered steel blade.
- Fixed protection ring around the blade.
- Fence plate safety lock as standard.
- Ventilated motor on all models.
- Available in version cold meats (S) and in version meat plate (C).

MODELLO MODEL	PREZZO PRICE	TIPO PIATTO PLATE TYPE	POTENZA WATT POWER WATT	ALIMENTAZIONE POWER SUPPLY	Ø LAMA mm Ø BLADE mm	TAGLIO UTILE mm USEFUL CUT mm	RPM		DIMENSIONI INGOMBRO MAX mm MAX OVERALL DIMENSIONS mm	DISTANZA TRA PIEDINI mm DISTANCE BETWEEN THE FEET mm	PESO NETTO Kg NET WEIGHT Kg	PESO LORDO Kg GROSS WEIGHT Kg	DIMENSIONI IMBALLO cm PACKING DIMENSIONS cm	MODELLO MODEL
PIATTO SALUMI COLD MEATS	SV250SP	€ 2.070,00	S	260	230/1N/50	250	240x170	300	520x610x515h	360x460	24,00	34,00	70x63x63h	SV250SP
	SV300RSP	€ 2.110,00	S	260	230/1N/50 or 400/3/50	300	240x190	300	520x610x515h	360x460	28,00	40,00	70x63x63h	SV300RSP
	SV300SP	€ 2.710,00	S	260	230/1N/50 or 400/3/50	300	260x200	280	550x710x610h	420x530	35,00	47,00	70x63x63h	SV300SP
	SV330SP	€ 2.790,00	S	370	230/1N/50 or 400/3/50	330	260x210	280	550x710x610h	420x530	36,00	48,00	70x63x63h	SV330SP
	SVN350SP	€ 3.260,00	S	370	230/1N/50 or 400/3/50	350	330x250	260	650x820x640h	530x650	44,00	55,00	82x72x76h	SVN350SP
	SVN370SP	€ 3.370,00	S	370	230/1N/50 or 400/3/50	370	330x260	260	650x820x640h	530x650	47,00	59,00	82x72x76h	SVN370SP
PIATTO CARNE MEATS	SV250CP	€ 2.070,00	C	260	230/1N/50	250	215x170	300	520x610x500h	360x460	24,00	34,00	70x63x63h	SV250CP
	SV300RCP	€ 2.110,00	C	260	230/1N/50 or 400/3/50	300	215x200	300	520x610x500h	360x460	28,00	40,00	70x63x63h	SV300RCP
	SV300CP	€ 2.710,00	C	260	230/1N/50 or 400/3/50	300	260x200	280	550x710x550h	420x530	35,00	47,00	70x63x63h	SV300CP
	SV330CP	€ 2.790,00	C	370	230/1N/50 or 400/3/50	330	260x210	280	550x710x550h	420x530	36,00	48,00	70x63x63h	SV330CP
	SVN350CP	€ 3.260,00	C	370	230/1N/50 or 400/3/50	350	360x250	260	650x820x640h	530x650	44,00	55,00	82x72x76h	SVN350CP
	SVN370CP	€ 3.370,00	C	370	230/1N/50 or 400/3/50	370	360x260	260	650x820x640h	530x650	47,00	59,00	82x72x76h	SVN370CP

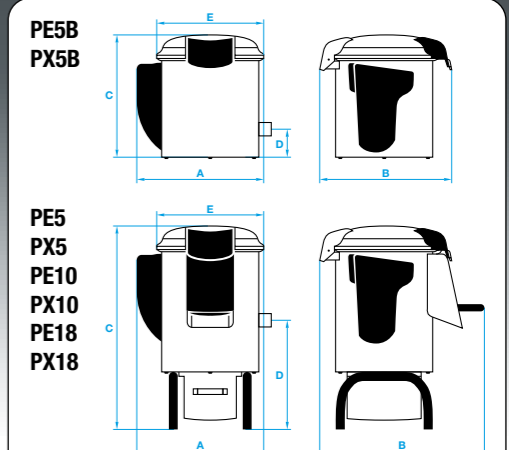

	A mm	B mm	C mm	D mm	E mm
PE5B	530	520	520	160	440
PX5B	/	520	520	160	440
PE5	530	520	700	350	440
PX5	/	520	700	350	440
PE10	530	660	850	350	440
PX10	/	660	850	350	440
PE18	530	660	950	350	440
PX18	/	660	950	350	440

- Realizzati completamente in acciaio inox AISI304 con particolari in materiale plastico di elevata resistenza meccanica.
- Sono dotati di serie di abrasivo laterale (facilmente asportabile con le mani) e piattello patate in fusione di alluminio ricoperto da spesso strato di carborundum.
- La versione CE professionale adotta una scheda elettronica digitale che gestisce tutti i comandi, l'elettrovalvola per il getto di acqua e il microinterruttore sul coperchio e sullo sportello di scarico.
- Tutti i modelli sono predisposti per l'inserimento del cassetto con filtro e hanno la possibilità dello scarico a terra o a parete (escluso il modello da 5 kg da banco).
- Su richiesta è disponibile il coperchio in acciaio inox AISI304.

- Made entirely of AISI304 stainless steel with plastic components of high mechanical resistance.
- They are equipped with standard abrasive on the side (easily removable by hand) and potato disk in cast aluminium covered with high thickness carborundum.
- The CE professional version adopts electronic digital board that controls all commands, the electronic valve for the water jet and the micro switch, both on the lid and on the discharge door.
- All models are predisposed for the insertion of the drawer with filter and have the possibility to allow the discharge on the ground or to the wall (except for the model 5 kg countertop).
- Upon request a lid in AISI304 stainless steel is available.

DWF	Cassetto con filtro	Drawer with filter	€ 290,00
-----	---------------------	--------------------	----------

MODELLO MODEL	PREZZO PRICE	POTENZA WATT POWER WATT	ALIMENTAZIONE POWER SUPPLY	RPM	PRODUZIONE ORARIA Kg/h HOURLY PRODUCTION Kg/h	TEMPO CICLO secondi CYCLE TIME seconds	Ø SCARICO LATERALE mm Ø SIDE DISCHARGE mm	Ø SCARICO INFERIORE mm Ø LOWER DISCHARGE mm	DIMENSIONI mm DIMENSIONS mm	PESO NETTO Kg NET WEIGHT Kg	PESO LORDO Kg GROSS WEIGHT Kg	DIMENSIONI IMBALLO cm PACKING DIMENSIONS cm	MODELLO MODEL
PE5B CE PRO	€ 2.270,00	370	230/1N/50 or 230-400/3/50	270	150	60 - 90	50	-	530x520x520h	28,00	36,00	80x60x87h	PE5B CE PRO
PX5B EXTRA CE	€ 2.060,00	370	230/1N/50 or 230-400/3/50	270	150	60 - 90	50	-	440x520x520h	28,00	36,00	80x60x87h	PX5B EXTRA CE
PE5 CE PRO	€ 2.300,00	370	230/1N/50 or 230-400/3/50	270	150	60 - 90	50	40	530x520x700h	35,00	44,00	80x60x87h	PE5 CE PRO
PX5 EXTRA CE	€ 2.190,00	370	230/1N/50 or 230-400/3/50	270	150	60 - 90	50	40	440x520x700h	35,00	44,00	80x60x87h	PX5 EXTRA CE
PE10 CE PRO	€ 2.750,00	550	230/1N/50 or 230-400/3/50	320	300	90 - 120	50	40	530x660x850h	40,00	50,00	80x60x100h	PE10 CE PRO
PX10 EXTRA CE	€ 2.640,00	550	230/1N/50 or 230-400/3/50	320	300	90 - 120	50	40	440x660x850h	40,00	50,00	80x60x100h	PX10 EXTRA CE
PE18 CE PRO	€ 2.930,00	900	230/1N/50 or 230-400/3/50	320	500	120 - 150	50	40	530x660x950h	45,00	55,00	80x60x110h	PE18 CE PRO
PX18 EXTRA CE	€ 2.830,00	900	230/1N/50 or 230-400/3/50	320	500	120 - 150	50	40	440x660x950h	45,00	55,00	80x60x110h	PX18 EXTRA CE



- Struttura in acciaio inox AISI304 con particolari in materiale plastico ad elevata resistenza meccanica.
- Abrasivo laterale facilmente smontabile.
- Scheda elettronica di controllo.
- Elettrovalvola per spruzzo acqua.
- Micro di sicurezza su coperchio e sportello (LE10).
- I modelli LE5 e LE10 sono predisposti per l'utilizzo del cassetto con filtro DWF (optional).
- Su richiesta è disponibile il coperchio in acciaio inox AISI304.

- Structure made of AISI304 with plastic components of high mechanical resistance.
- Easily removable side abrasive.
- Electronic control board.
- Electronic valve for water jet.
- Safety microswitch on the top lid and on the discharge door (LE10).
- The models LE5 and LE10 can be equipped with the drawer with filter DWF (optional).
- Upon request, they can be equipped with a lid in AISI304 stainless steel.

- Robusta struttura in alluminio anodizzato.
- Vasca in acciaio inox.
- Tre micro interruttori di sicurezza.
- Coperchio in policarbonato trasparente.
- In dotazione gruppo coltello con due lame taglienti in acciaio inox.
- Optional: gruppo coltello con lame forate per mescolare.

- Sturdy anodised aluminium body.
- Stainless steel bowl.
- Three safety microswitches.
- Transparent polycarbonate lid.
- Includes cutter with two sharp stainless steel blades.
- Optional: cutter assembly with perforated blades for mixing.



DWF	Cassetto con filtro	Drawer with filter	€ 290,00
------------	---------------------	--------------------	-----------------

LAME IN ACCIAIO STAINLESS STEEL BLADES	DIMENSIONI mm DIMENSIONS mm	PESO NETTO Kg NET WEIGHT Kg	PESO LORDO Kg GROSS WEIGHT Kg	DIMENSIONI IMBALLO cm PACKING DIMENSIONS cm	PREZZO PRICE
GL3	ø200x86h	0,50	0,80	21x21x15h	€ 150,00
GM3 (OPTIONAL)	ø200x86h	0,50	0,80	21x21x15h	€ 230,00
GL5	ø200x115h	0,60	0,90	21x21x15h	€ 200,00
GM5 (OPTIONAL)	ø200x115h	0,60	0,90	21x21x15h	€ 270,00
GL8	ø200x147h	0,70	1,00	21x21x15h	€ 230,00
GM8 (OPTIONAL)	ø200x147h	0,70	1,00	21x21x15h	€ 300,00

MODELLO MODEL	PREZZO PRICE	POTENZA WATT POWER WATT	ALIMENTAZIONE POWER SUPPLY	RPM	PRODUZIONE ORARIA Kg/h HOURLY PRODUCTION Kg/h	TEMPO CICLO secondi CYCLE TIME seconds	Ø SCARICO LATERALE mm Ø SIDE DISCHARGE mm	Ø SCARICO INFERIORE mm Ø LOWER DISCHARGE mm	CAPACITÀ VASCA lt. BOWL CAPACITY lt.	CAPACITÀ MAX LIQUIDO lt. MAX LIQUID CAPACITY lt.	DIMENSIONI mm DIMENSIONS mm	PESO NETTO Kg NET WEIGHT Kg	PESO LORDO Kg GROSS WEIGHT Kg	DIMENSIONI IMBALLO cm PACKING DIMENSIONS cm	MODELLO MODEL
LE5B CE PRO	€ 2.630,00	370	230/1N/50 or 230-400/3/50	145	75	90 - 120	50	-	-	-	530x520x520h	28,00	36,00	67x60x87h	LE5B CE PRO
LE5 CE PRO	€ 2.750,00	370	230/1N/50 or 230-400/3/50	145	75	90 - 120	50	40	-	-	530x520x700h	35,00	44,00	67x60x87h	LE5 CE PRO
LE10 CE PRO	€ 3.120,00	370	230/1N/50 or 230-400/3/50	180	150	120 - 150	50	40	-	-	530x660x850h	40,00	50,00	67x60x100h	LE10 CE PRO
CT3	€ 1.070,00	370	230/1N/50	1400	-	-	-	-	3 (ø210x110h mm)	1,70	400x320x320h	12,00	14,00	47x38x38h	CT3
CT5	€ 1.790,00	750	230/1N/50	1400	-	-	-	-	5 (ø210x155h mm)	2,60	560x320x440h	27,00	30,00	63x53x51h	CT5
CT8	€ 1.870,00	750	230/1N/50	1400	-	-	-	-	8 (ø210x230h mm)	2,60	560x320x440h	28,00	31,00	63x53x51h	CT8



- Macchina ideale per ristoranti, mense, comunità e pizzerie fino a 1500 pasti.
- Coperchio smontabile per agevolare la pulizia.
- Motore ventilato con protezione termica.
- Comandi 24V e microinterruttore su coperchio e maniglia.
- Disponibili solo in versione CE.
- I modelli TA30-30K hanno la struttura in acciaio inox AISI304 e in alluminio.
- Il modello TA80V ha tutta la struttura in AISI304 con trattamento anticorrosione ed antiaderente per una facile pulizia.
- Trasmissione a cinghia
- Il modello TA30K è corredato di 5 dischi inclusi: E2, E10, H10, D10 e Z4.

- *Ideal machine for restaurants, cafeterias, communities and pizzerias up to 1500 meals.*
- *Removable cover for an easy cleaning.*
- *Ventilated motor with thermal protection.*
- *24V control and microswitch on cover and handle.*
- *Available only in CE version.*
- *The model TA30-30K have a structure in stainless steel AISI304 and aluminum.*
- *The model TA80V is entirely in AISI304 with anti-corrosive and non-stick surface for an easy cleaning.*
- *Belt drive*
- *The model TA30K have 5 discs included: E2, E10, H10, D10 and Z4.*

MODELLO	PREZZO	POTENZA WATT	ALIMENTAZIONE	PRODUZIONE ORARIA Kg/h	RPM	DIMENSIONI mm	PESO NETTO Kg	PESO LORDO Kg	DIMENSIONI IMBALLO cm
MODEL	PRICE	POWER WATT	POWER SUPPLY	HOURLY PRODUCTION Kg/h		DIMENSIONS mm	NET WEIGHT Kg	GROSS WEIGHT Kg	PACKING DIMENSIONS cm
TA30	€ 1.400,00	380	230/1N/50	100 - 300	320	570x240x470h	18,50	21,00	31x65x55h
TA30K	€ 1.950,00	380	230/1N/50	100 - 300	320	570x240x470h	20,50	23,00	31x65x55h
TA80V	€ 2.180,00	600	400/3/50	100 - 450	400	580x265x520h	21,00	23,00	30x64x52h

PER MODELLI / FOR MODELS TA30 - TA30K - TA80V - TA25K

I dischi E3, E4, E6, E8, E10, E14 possono essere forniti (a richiesta) con lama ondulata. I dischi della serie E possono essere forniti (a richiesta) con lama seghettata.

The discs E3, E4, E6, E8, E10, E14 can be supplied (on request) with corrugated blade. The discs of the E series can be supplied (on request) with serrated blade.

Dischi per affettare prodotti morbidi E1, E2, E3, E4, E5, E1S, E2S

Discs for slicing soft products E1, E2, E3, E4, E5, E1S, E2S

Dischi per affettare Tutti i modelli E

Discs for slices All models E

Dischi per bastoncino Tutti i modelli H; tutti i modelli B accoppiati con E8, E10, E14

Discs for sticks All models H; all models B to use in combination with E8, E10, E14

Dischi per cubettare Tutti i modelli D accoppiati con E8, E10, E14

Discs for cubes All models D to use in combination with E8, E10, E14

Dischi per sfilacciare/julienne Tutti i modelli Z

Discs for shredding All models Z

E1		€ 90,00	1 mm	Tutti / All
E2		€ 90,00	2 mm	Tutti / All
E3		€ 90,00	3 mm	Tutti / All
E4		€ 90,00	4 mm	Tutti / All
E6		€ 90,00	6 mm	Tutti / All
E5		€ 90,00	5 mm	Tutti / All
E1S		€ 90,00	1 mm	Tutti / All
E2S		€ 90,00	2 mm	Tutti / All
E8		€ 90,00	8 mm	Tutti / All
E10		€ 90,00	10 mm	Tutti / All
E14		€ 90,00	14 mm	Tutti / All
B6		€ 120,00	6 mm	TA30-30K
B8		€ 120,00	8 mm	TA30-30K
B10		€ 120,00	10 mm	TA30-30K
H2,5		€ 120,00	2,5 mm	Tutti / All
H4		€ 120,00	4 mm	Tutti / All
H6		€ 120,00	6 mm	Tutti / All
H8		€ 120,00	8 mm	Tutti / All
H10		€ 120,00	10 mm	Tutti / All
Z4		€ 85,00	4 mm	Tutti / All
Z7		€ 85,00	7 mm	Tutti / All
Z2		€ 85,00	2 mm	Tutti / All
Z3		€ 85,00	3 mm	Tutti / All
Z4		€ 85,00	4 mm	Tutti / All
Z7		€ 85,00	7 mm	Tutti / All
PZ4		€ 115,00	4 mm	Tutti / All
PZ7		€ 115,00	7 mm	Tutti / All
DG8S		€ 285,00	8 mm	TA80V
DG10S		€ 285,00	10 mm	TA80V
DG12S		€ 285,00	12 mm	TA80V
V		€ 85,00	Grattugia Grating	Tutti All
D8S		€ 155,00	8 mm	TA30-30K
D10S		€ 155,00	10 mm	TA30-30K
D12S		€ 155,00	12 mm	TA30-30K



Mixer ad immersione serie MK 2

Stick blenders MK 2 series



- Mixer per uso professionale ideale per ristoranti, alberghi, pasticcerie e gelaterie.
- Il corpo motore è realizzato in plastica antiurto.
- Il mescolatore da 250mm è in acciaio inox.
- Motore ventilato.
- Variatore di velocità e frusta sul modello MK225VF.

- *Stick blender for professional equipment particularly suited for restaurants, hotels, bakeries and ice cream shops.*
- *The body is made of impact resistant plastic.*
- *Mixer 250mm made of stainless steel.*
- *Ventilated motor.*
- *Speed regulator and whip on model MK225VF.*

MODELLO MODEL	PREZZO PRICE	POTENZA WATT POWER WATT	ALIMENTAZIONE POWER SUPPLY	RPM	CAPACITÀ VASCA IT. BOWL CAPACITY It.	DIMENSIONI mm DIMENSIONS mm	PESO NETTO Kg NET WEIGHT Kg	PESO LORDO Kg GROSS WEIGHT Kg	DIMENSIONI IMBALLO cm PACKING DIMENSIONS cm	MODELLO MODEL
MK250	€ 310,00	250	230/1N/50-60	15.000	20	Ø 75x285h	1,00	1,50	39x12x9h	MK250
MK250V	€ 380,00	250	230/1N/50	2.500 ÷ 15.000	20	Ø 75x285h	1,00	1,50	39x12x9h	MK250V
MK005 (frusta / whisk)	€ 170,00	-	-	-	-	290x90	0,50	1,00	39x12x9h	MK005 (frusta / whisk)
MK025 (mescolatore / mixer)	€ 130,00	-	-	-	-	Ø 75x270h	0,50	1,00	39x12x9h	MK025 (mescolatore / mixer)
MK025E (emulsionatore / emulsifier)	€ 210,00	-	-	-	-	Ø 75x270h	0,50	1,00	39x12x9h	MK025E (emulsionatore / emulsifier)
MK225 (MK250 + MK025)	€ 390,00	250	230/1N/50-60	15.000	20	-	1,50	2,00	25x36x8h	MK225 (MK250 + MK025)
MK225VF (MK250V + MK005 + MK025)	€ 540,00	250	230/1N/50	2.500 ÷ 15.000	20	-	1,90	2,50	25x36x8h	MK225VF (MK250V + MK005 + MK025)



Mixer ad immersione MK SERIES 3-4

Stick blenders MK SERIES 3-4

Dettaglio comandi MK300-400
Control board view MK300-400



- Mixer per uso professionale ideale per ristoranti, alberghi, pasticcerie e gelaterie.
- Il corpo motore è realizzato in plastica antiurto.
- I mescolatori e le fruste sono in acciaio inox.
- Il motore ventilato, la termica di protezione e la scheda elettronica con controllo della velocità e potenza, garantiscono una lavorazione rapida ed omogenea.
- Display.
- Giunto millerighe ad alta resistenza.
- Utensili ad innesto rapido.

- *Stick blender for professional equipment particularly suited for restaurants, hotels, bakeries and ice cream shops.*
- *The body is made of impact resistant plastic.*
- *Mixers and whisks are made of stainless steel.*
- *The ventilated motor, the thermal protection and the electronic control board with speed and power control, ensure a fast and uniform work processing.*
- *Display.*
- *High resistance ribbed coupling joint.*
- *Tools with quick coupling.*

MODELLO MODEL	PREZZO PRICE	POTENZA WATT POWER WATT	ALIMENTAZIONE POWER SUPPLY	RPM	CAPACITÀ VASCA It. BOWL CAPACITY It.	DIMENSIONI mm DIMENSIONS mm	PESO NETTO Kg NET WEIGHT Kg	PESO LORDO Kg GROSS WEIGHT Kg	DIMENSIONI IMBALLO cm PACKING DIMENSIONS cm	MODELLO MODEL
MK300	€ 430,00	300	230/1N/50-60	2.000÷13.000	-	∅ 100x350h	1,80	2,30	44x19x16h	MK300
MK400	€ 520,00	400	230/1N/50-60	2.000÷15.000	-	∅ 100x350h	2,10	2,60	44x19x16h	MK400
MK010 (frusta / whisk)	€ 240,00	-	-	-	-	330x120	1,00	1,50	39x12x9h	MK010 (frusta / whisk)
MK030 (mescolatore / mixer)	€ 190,00	-	-	-	-	∅ 85x340h	0,90	1,40	65x10x10h	MK030 (mescolatore / mixer)
MK040 (mescolatore / mixer)	€ 200,00	-	-	-	-	∅ 85x440h	1,00	1,50	65x10x10h	MK040 (mescolatore / mixer)
MK050 (mescolatore / mixer)	€ 220,00	-	-	-	-	∅ 85x540h	1,20	1,70	65x10x10h	MK050 (mescolatore / mixer)
MK330 (MK300 + MK010 + MK030)	€ 850,00	300	230/1N/50-60	2.000÷13.000	30/50	-	3,50	4,00	35x47x14h	MK330 (MK300 + MK010 + MK030)
MK340 (MK300 + MK010 + MK040)	€ 860,00	300	230/1N/50-60	2.000÷13.000	50/80	-	3,60	4,10	35x47x14h	MK340 (MK300 + MK010 + MK040)
MK350 (MK300 + MK010 + MK050)	€ 880,00	300	230/1N/50-60	2.000÷13.000	80/100	-	3,80	4,30	80x30x14h	MK350 (MK300 + MK010 + MK050)
MK430 (MK400 + MK010 + MK030)	€ 930,00	400	230/1N/50-60	2.000÷15.000	30/50	-	3,80	4,30	35x47x14h	MK430 (MK400 + MK010 + MK030)
MK440 (MK400 + MK010 + MK040)	€ 940,00	400	230/1N/50-60	2.000÷15.000	50/80	-	3,90	4,40	35x47x14h	MK440 (MK400 + MK010 + MK040)
MK450 (MK400 + MK010 + MK050)	€ 960,00	400	230/1N/50-60	2.000÷15.000	80/100	-	4,10	4,60	80x30x14h	MK450 (MK400 + MK010 + MK050)



MG8A-MG12-MG22

- Struttura in lega di alluminio pressofuso e lamiera con acciaio inox AISI304 sul corpo motore.
- Riduttore ad ingranaggi elicoidali a bagno d'olio.
- Motore asincrono con protezione termica.
- Gruppo di macinazione inox su MG12IX, MG12I, MG22IX, MG22I.
- Gruppo di macinazione in ghisa alimentare su MG12GX, MG22GX.
- Coclea in alluminio su MG8A e MG8AX.
- Disponibili in versione a norme CE e senza norme ce (versioni X).
- In dotazione: Piastra Ø6 mm, coltello, pestello e vaschetta carne.

MG8A-MG12-MG22

- *Pressure die cast aluminium alloy structure with AISI304 stainless steel plate motor cover.*
- *Geared oil immersed speed reducer.*
- *Asynchronous motor with thermal protection.*
- *Stainless steel mincing unit on MG12IX, MG12I, MG22IX, MG22I.*
- *Cast iron mincing unit on MG12GX, MG22GX.*
- *Aluminium screw shaft on MG8A and MG8AX.*
- *Available in CE norms compliant version s and without CE norms (versions X).*
- *Standard equipment: Plate Ø6 mm, knife, pestle and meat pan.*

MG22CI-MG32CI

- Struttura in acciaio inox.
- Riduttore ad ingranaggi elicoidali a bagno d'olio.
- Motore asincrono ventilato con protezione termica.
- Gruppo di macinazione inox.
- Inversione di marcia.
- In dotazione: Piastra Ø 6mm, coltello, pestello, vaschetta carne.

MG22CI-MG32CI

- *Stainless steel structure.*
- *Geared oil immersed speed reducer.*
- *Asynchronous ventilated motor with thermal protection.*
- *Stainless steel mincing unit.*
- *Gear inversion.*
- *Standard equipment: Plate Ø 6mm, knife, pestle and meat pan.*

MODELLO MODEL	PREZZO PRICE	POTENZA WATT POWER WATT	ALIMENTAZIONE POWER SUPPLY	PRODUZIONE ORARIA Kg PRODUCTION PER HOUR Kg	DIMENSIONI mm DIMENSIONS mm	PESO NETTO Kg (1Ph/3Ph) NET WEIGHT Kg (1Ph/3Ph)	PESO LORDO Kg (1Ph/3Ph) GROSS WEIGHT Kg (1Ph/3Ph)	DIMENSIONI IMBALLO cm PACKING DIMENSIONS cm	MODELLO MODEL
MG8A	€ 630,00	380	230/1N/50	20	270x260x360h	9,0	10,0	31x26x37h	MG8A
MG8AX	€ 710,00	380	230/1N/50	20	270x260x360h	9,0	10,0	31x26x37h	MG8AX
MG12I	€ 1.350,00	750	230/1N/50 or 400/3/50	200	370x220x440h	19,0 / 16,0	21,0 / 18,0	44x25x44h	MG12I
MG12IX	€ 1.310,00	750	230/1N/50 or 400/3/50	200	370x220x440h	19,0 / 16,0	21,0 / 18,0	44x25x44h	MG12IX
MG12GX	€ 990,00	750	230/1N/50 or 400/3/50	200	370x220x440h	19,0 / 16,0	21,0 / 18,0	44x25x44h	MG12GX
MG22I	€ 1.600,00	1100	230/1N/50 or 400/3/50	300	440x240x510h	24,0 / 22,0	26,5 / 24,5	48x30x51h	MG22I
MG22IX	€ 1.620,00	1100	230/1N/50 or 400/3/50	300	440x240x510h	24,0 / 22,0	26,5 / 24,5	48x30x51h	MG22IX
MG22GX	€ 1.160,00	1100	230/1N/50 or 400/3/50	300	440x240x510h	24,0 / 22,0	26,5 / 24,5	48x30x51h	MG22GX
MG22CI	€ 3.230,00	1500	230/1N/50	400	435x260x525h	35,0	38,0	59x37x55h	MG22CI - 230V 1Ph
MG22CI	€ 3.070,00	1500	230-400/3/50	400	435x260x525h	34,0	37,0	59x37x55h	MG22CI - 230/400V 3Ph
MG32CI	€ 3.500,00	1600	230/1N/50	500	510x260x525h	40,0	43,0	59x37x55h	MG32CI - 230V 1Ph
MG32CI	€ 3.130,00	1600	230-400/3/50	500	510x260x525h	40,0	43,0	59x37x55h	MG32CI - 230/400V 3Ph



Abbinati tritacarne / grattugia AB Meat mincers / graters AB



Grattugie Graters



- Struttura in lega di alluminio pressofuso con lamiera in acciaio inox AISI304 sul corpo motore.
- Riduttore ad ingranaggi elicoidali a bagno d'olio.
- Motore asincrono con protezione termica.
- Gruppo di macinazione inox su AB12IX, AB12I, AB22IX, AB22I.
- Gruppo di macinazione in ghisa alimentare su AB12GX, AB22GX.
- Coclea in alluminio su AB8A e AB8AX.
- Rullo grattugia in acciaio inox.
- Grattugia con griglia inferiore di protezione e microinterruttore di sicurezza sulla leva.
- Disponibili in versione a norme CE e senza norme ce (versioni X).
- In dotazione: Piastra Ø6 mm, coltello, pestello, vaschetta carne e scodella formaggio in acciaio inox.

- Pressure die cast aluminium alloy structure with AISI304 stainless steel plate motor cover.
- Geared oil immersed speed reducer.
- Asynchronous motor with thermal protection.
- Stainless steel mincing unit on AB12IX, AB12I, AB22IX, AB22I.
- Cast iron mincing unit on AB12GX, AB22GX.
- Aluminium screw shaft on AB8A and AB8AX.
- Grating roll in stainless steel.
- Available in CE norms compliant versions and without CE norms (versions X).
- Grater with lower protection grid and safety microswitch on the lever.
- Standard equipment: Plate Ø6 mm, knife, meat pan, pestle and cheese collection bowl in stainless steel.

GRF

- Struttura in alluminio anodizzato.
- Rullo in acciaio inox.
- Griglia inferiore di protezione.
- Microinterruttore sulla leva.
- In dotazione vaschetta raccolta formaggio in acciaio inox.

GRF8I - GRF12I

- Struttura in alluminio pressofuso lucidato.
- Motore ventilato.
- Rullo in acciaio inox.
- Griglia inferiore di protezione.
- Microinterruttore sulla leva.
- In dotazione vaschetta raccolta formaggio in acciaio inox.
- Modello GRF12I disponibile su richiesta con bocca grattugia sul lato destro.

GRF

- Anodized aluminium body.
- Stainless steel roller.
- Lower protection grid.
- Micro-switch on the lever.
- Included cheese collection bowl in stainless steel.

GRF8I - GRF12I

- Die-cast and polished aluminium body.
- Ventilated motor.
- Stainless Steel roller.
- Lower protection grid.
- Micro-switch on the lever.
- Included cheese collection bowl in stainless steel.
- GRF12I model available on request with grater mouth on the right side

MODELLO MODEL	PREZZO PRICE	POTENZA WATT POWER WATT	ALIMENTAZIONE POWER SUPPLY	PRODUZIONE ORARIA TRITACARNE Kg/h MEAT MINCER HOURLY PRODUCTION Kg/h	PRODUZIONE ORARIA GRATTUGIA Kg/h GRATER HOURLY PRODUCTION Kg/h	DIMENSIONI mm DIMENSIONS mm	PESO NETTO Kg (1Ph/3Ph) NET WEIGHT Kg (1Ph/3Ph)	PESO LORDO Kg (1Ph/3Ph) GROSS WEIGHT Kg (1Ph/3Ph)	DIMENSIONI IMBALLO cm PACKING DIMENSIONS cm	MODELLO MODEL
AB8A	€ 770,00	380	230/1N/50	20	30	380x260x360h	10,0	11,0	38x31x36h	AB8A
AB8AX	€ 750,00	380	230/1N/50	20	30	380x260x360h	10,0	11,0	38x31x36h	AB8AX
AB12I	€ 1.790,00	750	230/1N/50 or 400/3/50	200	50	550x200x460h	22,0 / 20,0	24,5 / 22,5	59x30x43h	AB12I - 1ph/3ph
AB12IX	€ 1.750,00	750	230/1N/50 or 400/3/50	200	50	550x200x460h	22,0 / 20,0	24,5 / 22,5	59x30x43h	AB12IX - 1ph/3ph
AB12GX	€ 1.410,00	750	230/1N/50 or 400/3/50	200	50	550x200x460h	22,0 / 20,0	24,5 / 22,5	59x30x43h	AB12GX - 1ph/3ph
AB22I	€ 1.930,00	1100	230/1N/50 or 400/3/50	300	70	610x220x460h	27,0 / 25,0	30,0 / 28,0	72x29x44h	AB22I - 1ph/3ph
AB22IX	€ 1.900,00	1100	230/1N/50 or 400/3/50	300	70	610x220x460h	27,0 / 25,0	30,0 / 28,0	72x29x44h	AB22IX - 1ph/3ph
AB22GX	€ 1.630,00	1100	230/1N/50 or 400/3/50	300	70	610x220x460h	27,0 / 25,0	30,0 / 28,0	72x29x44h	AB22GX - 1ph/3ph
GRF12I	€ 1.100,00	750	230/1N/50 or 400/3/50	-	70	380x220x300h	16,00	18,00	40x31x41h	GRF12I
GRF8I	€ 520,00	370	230/1N/50	-	30	280x170x310h	9,00	11,00	31x26x37h	GRF8I
GRF	€ 680,00	185	230/1N/50	-	-	340x240x290h	8,00	9,00	28x33x41h	GRF



Sottovuoto a barra
Bar vacuum machines



Sottovuoto a campana
Chamber vacuum machines



FRESH33

FRESH33



FRESH43

FRESH43



FUSION42

Fusion42

FUSION36

Fusion36

- Macchine sottovuoto studiate per un uso semplice ed immediato nelle piccole realtà della ristorazione professionale (piccoli ristoranti, macellerie, negozi di alimentari, gastronomie, snack bar).
- Materiali di qualità che garantiscono un vuoto affidabile e durevole nel tempo.
- Funzionamento automatico con comandi estremamente semplici.
- Tutte le sottovuoto a barra sono dotate di pompa autolubrificante ad alto vuoto.
- Barra saldante professionale che garantisce una perfetta saldatura sia per buste goffrate normali che per buste goffrate per cottura.
- Predisposizione per vuoto in contenitori.
- Raccomandato utilizzo di sole buste goffrate.

- *Vacuum packing machines designed for simple and immediate use in small professional catering businesses (small restaurants, butchers, grocery stores, delicatessens, snack bars).*
- *Quality materials that guarantee a reliable and long-lasting vacuum.*
- *Automatic operation with extremely simple controls.*
- *All bar vacuum sealers are equipped with a high vacuum self-lubricating pump.*
- *Professional sealing bar that guarantees perfect sealing for both normal embossed bags and embossed bags for cooking.*
- *Predisposition for vacuum in containers.*
- *Recommended use of embossed envelopes only.*

- Sottovuoto a campana professionali con carcassa in acciaio inox AISI304 e coperchio in policarbonato da 15mm di spessore.
- Vasca stampata e stondata, priva di giunzioni e saldature sulle pareti.
- Pompa a bagno d'olio che garantisce il raggiungimento di un livello di vuoto al 99,9%.
- Barra saldante senza fili con pistoni in acciaio inox AISI304.
- 10 programmi personalizzabili.
- Regolazione del tempo di vuoto e di saldatura.
- Vuotometro per controllo qualità del vuoto.

- *Professional vacuum chamber machines with AISI304 stainless steel casing and 15mm thick polycarbonate lid.*
- *Moulded and rounded tank, without joints and welds on the walls.*
- *Oil pump that guarantees the achievement of a 99,9 % vacuum level.*
- *Wireless sealing bar with AISI304 stainless steel pistons.*
- *10 customizable programs.*
- *Vacuum and sealing time set-up.*
- *Vacuum meter to check vacuum quality.*

MODELLO MODEL	PREZZO PRICE	POTENZA WATT POWER WATT	ALIMENTAZIONE POWER SUPPLY	BARRA SALDANTE mm WELDING BAR mm	POMPA AUTOLUBRIFICANTE SELF LUBRICATING PUMP	DIMENSIONI CAMERA mm CHAMBER DIMENSIONS mm	DIMENSIONI mm DIMENSIONS mm	PESO NETTO Kg NET WEIGHT Kg	PESO LORDO Kg GROSS WEIGHT Kg	DIMENSIONI IMBALLO cm PACKING DIMENSIONS cm	MODELLO MODEL
FRESH33	€ 580,00	380	230/1N/50-60	330	10 l/min	-	385x300x170h	6,0	7,0	47x31x23h	FRESH33
FRESH43	€ 960,00	450	230/1N/50-60	430	20 l/min	-	470x305x180h	8,0	9,5	60x33x27	FRESH43
FUSION36	€ 3.900,00	370	230/1N/50-60	365	10 m3/h	370x440x215h	510x560x520h	48,0	58,0	68x66x75h	FUSION36
FUSION42	€ 4.300,00	750	230/1N/50-60	420	20 m3/h	430x430x220h	560x560x520h	62,0	72,0	68x66x75h	FUSION42

